

Signals and Systems

Robby McWilliam

November 18, 2013

Contents

1	Signals and systems	3
1.1	Properties of signals	3
1.2	Systems (functions of signals)	4
1.3	Some important systems	8
1.4	Properties of systems	9
1.5	Exercises	11
2	Systems modelled by differential equations	16
2.1	Passive circuits	18
2.2	Active circuits	19
2.3	Masses, springs and dampers	26
2.4	Direct current motors	28
2.5	Exercises	29
3	Linear time-invariant systems	31
3.1	Convolution, regular systems and the delta “function”	31
3.2	Properties of convolution	35
3.3	Linear combining and composition	36
3.4	Eigenfunctions and the transfer function	38
3.5	The spectrum	40
3.6	Exercises	44
4	The Laplace transform	46
4.1	The transfer function and the Laplace transform	49
4.2	Solving differential equations	52
4.3	First order systems	52
4.4	Second order systems	55
4.5	Poles, zeros, and stability	59
4.6	Exercises	67

5	The Fourier transform	75
5.1	Duality and the inverse transform	76
5.2	Parseval's identity	79
5.3	Ideal filters	80
5.4	Butterworth filters	81
5.5	Sampling and interpolation	88
5.6	Exercises	90

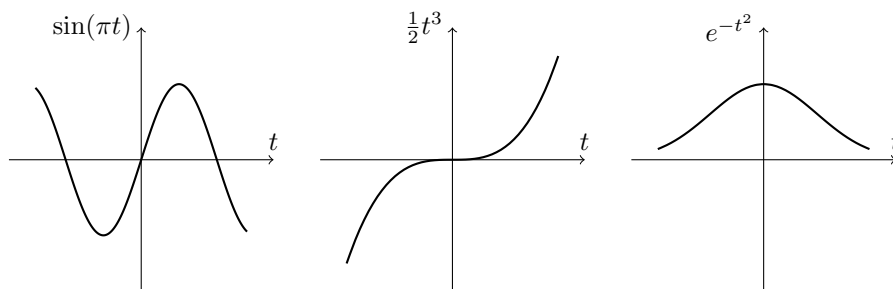

Figure 1: 1-dimensional continuous-time signals

1 Signals and systems

A **signal** is a function mapping an input variable to some output variable. For example

$$\sin(\pi t), \quad \frac{1}{2}t^3, \quad e^{-t^2}$$

all represent **signals** with input variable $t \in \mathbb{R}$, and they are plotted in Figure 1. If x is a signal and t an input variable we write $x(t)$ for the output variable. Signals can be multidimensional. This page is an example of a 2-dimensional signal, the independent variables are the horizontal and vertical position on the page, and the signal maps this position to a colour, in this case either black or white. A moving image such as seen on your television or computer monitor is an example of a 3-dimensional signal, the three independent variables being vertical and horizontal screen position and time. The signal maps each position and time to a colour on the screen. In this course we focus exclusively on 1-dimensional signals such as those in Figure 1 and we will only consider signals where the output variable is real or complex valued. Many of the results presented here can be extended to deal with multidimensional signals.

1.1 Properties of signals

A signal x is **bounded** if there exists a real number M such that

$$|x(t)| \leq M \quad \text{for all } t \in \mathbb{R}$$

where $|\cdot|$ denotes the (complex) magnitude. Both $\sin(\pi t)$ and e^{-t^2} are examples of bounded signals because $|\sin(\pi t)| \leq 1$ and $|e^{-t^2}| \leq 1$ for all $t \in \mathbb{R}$. However, $\frac{1}{2}t^3$ is not bounded because its magnitude grows indefinitely as t moves away from the origin.

A signal x is **periodic** if there exists a real number T such that

$$x(t) = x(t + kT) \quad \text{for all } k \in \mathbb{Z} \text{ and } t \in \mathbb{R}.$$

The smallest such nonnegative such T is called the **period**. For example, the signal $\sin(\pi t)$ is periodic with period $T = 2$. Neither $\frac{1}{2}t^3$ or e^{-t^2} are periodic.

A signal x is called **locally integrable** if for all finite constants a and b ,

$$\int_a^b |x(t)| dt$$

exists (evaluates to a finite number). An example of a signal that is not locally integrable is $x(t) = \frac{1}{t}$ (Exercise 1.2). Two signals x and y are equal, i.e. $x = y$ if $x(t) = y(t)$ for all $t \in \mathbb{R}$.

A signal x is called **absolutely integrable** if

$$\|x\|_1 = \int_{-\infty}^{\infty} |x(t)| dt \quad (1.1)$$

exists. Here we introduce the notation $\|x\|_1$ called the ℓ_1 -**norm** of x . For example $\sin(\pi t)$ and $\frac{1}{2}t^3$ are not absolutely integrable, but e^{-t^2} is because [Nicholas and Yates, 1950]

$$\int_{-\infty}^{\infty} |e^{-t^2}| dt = \int_{-\infty}^{\infty} e^{-t^2} dt = \sqrt{\pi}. \quad (1.2)$$

A signal x is called is **square integrable** if

$$\|x\|_2 = \int_{-\infty}^{\infty} |x(t)|^2 dt$$

exists. Square integrable signals are also called **energy signals**, and the value of $\|x\|_2$ is called the **energy** of x (it is also called the ℓ_2 -**norm** of x). For example $\sin(\pi t)$ and $\frac{1}{2}t^3$ are not energy signals, but e^{-t^2} is (Exercise 1.5).

A signal x is **right sided** if there exists a $T \in \mathbb{R}$ such that $x(t) = 0$ for all $t < T$. Correspondingly x is **left sided** if $x(t) = 0$ for all $T > t$. For example, the **step function**

$$u(t) = \begin{cases} 1 & t > 0 \\ 0 & t \leq 0 \end{cases} \quad (1.3)$$

is right-sided. Its reflection in time $u(-t)$ is left sided (Figure 2). A signal x is called **finite in time** if it is both left and right sided, that is, if there exists a $T \in \mathbb{R}$ such that $x(t) = x(-t) = 0$ for all $t > T$. A signal is called **unbounded in time** if it is neither left nor right sided. For example, the continuous time signals $\sin(\pi t)$ and e^{-t^2} are unbounded in time, but the **rectangular pulse**

$$\Pi(t) = \begin{cases} 1 & -\frac{1}{2} < t \leq \frac{1}{2} \\ 0 & \text{otherwise} \end{cases} \quad (1.4)$$

is finite in time.

1.2 Systems (functions of signals)

A **system** (also known as an **operator** or **functional**) maps a signal to another signal. For example

$$x(t) + 3x(t-1), \quad \int_0^1 x(t-\tau) d\tau, \quad \frac{1}{x(t)}, \quad \frac{d}{dt}x(t)$$

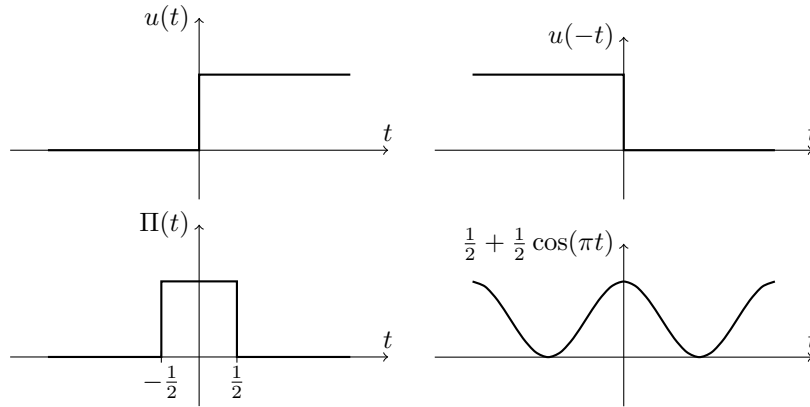

Figure 2: The right sided step function $u(t)$, its left sided reflection $u(-t)$, the finite in time rectangular pulse $\Pi(t)$ and the unbounded in time signal $\frac{1}{2} + \frac{1}{2} \cos(x)$.

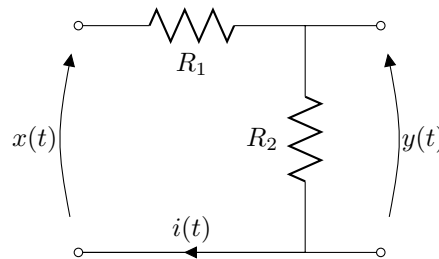

Figure 3: A **voltage divider** circuit.

represent systems, each mapping the signal x to another signal. Consider the electric circuit in Figure 3 called a **voltage divider**. If the voltage at time t is $x(t)$ then, by Ohm's law, the current at time t satisfies

$$i(t) = \frac{1}{R_1 + R_2} x(t),$$

and the voltage over the resistor R_2 is

$$y(t) = R_2 i(t) = \frac{R_2}{R_1 + R_2} x(t) \tag{1.5}$$

The circuit can be considered as a system mapping the signal x representing the voltage to the signal $i = \frac{1}{R_1 + R_2} x$ representing the current, or a system mapping x to the signal $y = \frac{R_2}{R_1 + R_2} x$ representing the voltage over resistor R_2 .

We denote systems with capital letters such as H and G . A system H is a function that maps a signal x to another signal denoted $H(x)$. We call x the **input signal** and $H(x)$ the **output signal** or the **response** of system H to signal x . If we want to include the independent variable t we will write $H(x)(t)$

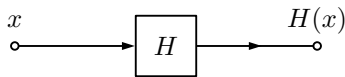

Figure 4: System block diagram with input signal x and output signal $H(x)$.

or $H(x, t)$ and do not distinguish between these [Curry and Feys, 1968]. It is sometimes useful to depict systems with a block diagram. Figure 4 is a simple block diagram showing the input and output signals of a system H .

Using this notation the electric circuit in Figure 3 corresponds with the system

$$H(x) = \frac{R_2}{R_1 + R_2} x = y.$$

This system multiplies the input signal x by $\frac{R_2}{R_1 + R_2}$. This brings us to our first practical test.

Test 1 (Voltage divider) In this test we construct the voltage divider from Figure 3 on a breadboard with resistors $R_1 \approx 100\Omega$ and $R_2 \approx 470\Omega$ with values accurate to within 5%. Using a computer soundcard (an approximation of) the voltage signal

$$x(t) = \sin(2\pi f_1 t) \quad \text{with} \quad f_1 = 100$$

is passed through the circuit. The approximation is generated by sampling $x(t)$ at rate $F_s = \frac{1}{T_s} = 44100\text{Hz}$ to generate samples

$$x_n = x(nT_s) \quad n = 0, \dots, 2F_s$$

corresponding to approximately 2 seconds of signal. These samples are passed to the soundcard which starts playback. The voltage over resistor R_2 is recorded (also using the soundcard) that returns a lists of samples y_1, \dots, y_L taken at rate F_s . The continuous-time voltage over R_2 can be (approximately) reconstructed from these samples as

$$\tilde{y}(t) = \sum_{\ell=1}^L y_\ell \text{sinc}(F_s t - \ell) \quad (1.6)$$

where

$$\text{sinc}(t) = \frac{\sin(\pi t)}{\pi t} \quad (1.7)$$

is the called the **sinc function** and is plotted in Figure 40. We will justify this reconstruction in Section 5.5. Simultaneously the (stereo) soundcard is used to record the input voltage $x(t)$ producing samples x_1, \dots, x_L taken at rate F_s . An approximation of the continuous-time input signal is

$$\tilde{x}(t) = \sum_{\ell=1}^L x_\ell \text{sinc}(F_s t - \ell). \quad (1.8)$$

In view of (1.5) we would expect the approximate relationship

$$\tilde{y} \approx \frac{R_2}{R_1 + R_2} \tilde{x} = \frac{42}{57} \tilde{x}$$

A plot of \tilde{y} , \tilde{x} and $\frac{42}{57}\tilde{x}$ over a 20ms period from 1s to 1.02s is given in Figure 5. The hypothesised output signal $\frac{42}{57}\tilde{x}$ does not match the observed output signal \tilde{y} . A primary reason is that the circuitry inside the soundcard itself cannot be ignored. When deriving the equation for the voltage divider we implicitly assumed that current flows through the output of the soundcard without resistance (a short circuit), and that no current flows through the input device of the soundcard (an open circuit). These assumptions are not realistic. Modelling the circuitry in the sound card wont be attempted here. In the next section we will construct circuits that contain external sources of power (active circuits). These are less sensitive to the circuitry inside the soundcard.

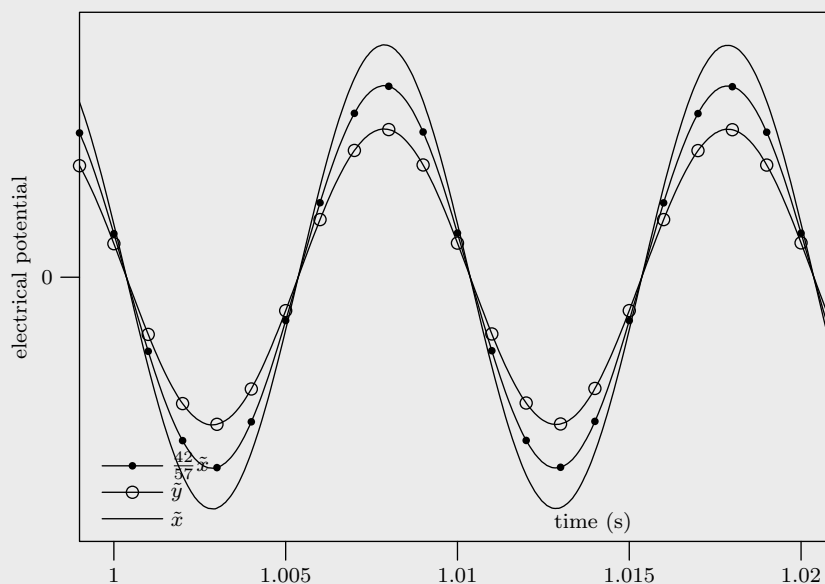

Figure 5: Plot of reconstructed input signal \tilde{x} (solid line), output signal \tilde{y} (solid line with circle) and hypothesised output signal $\frac{42}{57}\tilde{x}$ (solid line with dot) for the voltage divider circuit in Figure 3. The hypothesised signal does not match \tilde{y} . One reason is that the model does not take account of the circuitry inside the soundcard.

Not all signals can be input to all systems. For example, the system

$$H(x, t) = \frac{1}{x(t)}$$

is not defined at those t where $x(t) = 0$ because we cannot divide by zero.

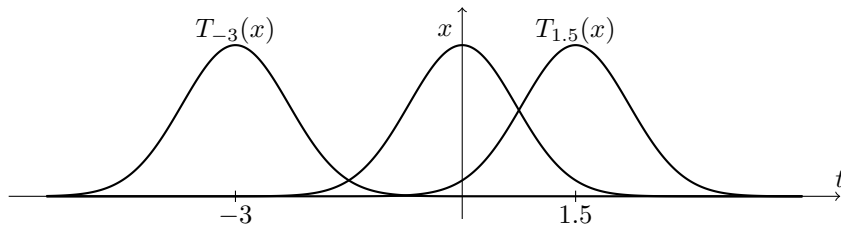

Figure 6: Time-shifter system $T_{1.5}(x, t) = x(t - 1.5)$ and $T_{-3}(x, t) = x(t + 3)$ acting on the signal $x(t) = e^{-t^2}$.

Another example is the system

$$I_{\infty}(x, t) = \int_{-\infty}^t x(\tau) d\tau, \quad (1.9)$$

called an **integrator**, that is not defined for those signals where the integral above does not exist (is not finite). For example, the signal $x(t) = 1$ cannot be input to the integrator since the integral $\int_{-\infty}^t dt$ does not exist.

Thus, when specifying a system it is necessary to also specify a set of signals that can be input, called a **domain** for the system. For example, a domain for the system $H(x, t) = \frac{1}{x(t)}$ is the set of signals $x(t)$ which are not zero for any t . A domain for the integrator $I_{\infty}(x, t)$ is the set of signals for which the integral $\int_{-\infty}^t x(\tau) d\tau$ exists for all $t \in \mathbb{R}$. The domain we use for a given system is usually obvious from the specification of the system itself. For this reason we will not usually state the domain explicitly. We will only do so if there is chance for confusion.

1.3 Some important systems

The system

$$T_{\tau}(x, t) = x(t - \tau)$$

is called the **time-shifter**. This system shifts the input signal along the t axis ('time' axis) by τ . When τ is positive T_{τ} delays the input signal by τ . The time-shifter will appear so regularly in this course that we use the special notation T_{τ} to represent it. Figure 6 depicts the action of time-shifters $T_{1.5}$ and T_{-3} on the signal $x(t) = e^{-t^2}$. When $\tau = 0$ the time-shifter is the **identity system**

$$T_0(x) = x$$

that maps the signal x to itself.

Another important system is the **time-scaler** that has the form

$$H(x, t) = x(\alpha t)$$

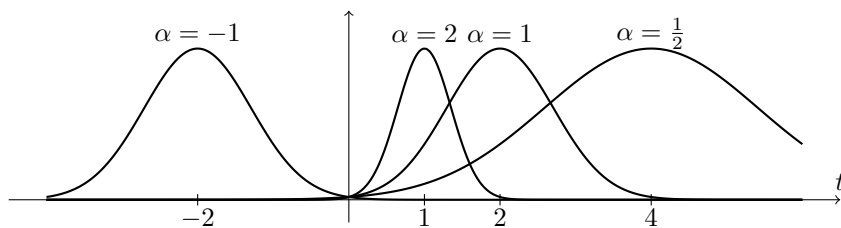

Figure 7: Time-scaler system $H(x, t) = x(\alpha t)$ for $\alpha = -1, \frac{1}{2}, 1$ and 2 acting on the signal $x(t) = e^{-(t-2)^2}$.

for $\alpha \in \mathbb{R}$. Figure 7 depicts the action of a time-scaler with a number of values for α . When $\alpha = -1$ the time-scaler reflects the input signal in the time axis. When $\alpha = 1$ the time-scaler is the identity system T_0 .

Another system we regularly encounter is the **differentiator**

$$D(x, t) = \frac{d}{dt}x(t),$$

that returns the derivative of the input signal. We also define a k th differentiator

$$D^k(x, t) = \frac{d^k}{dt^k}x(t)$$

that returns the k th derivative of the input signal.

A related system is the **integrator**

$$I_a(x, t) = \int_{-a}^t x(\tau) d\tau.$$

The parameter a describes the lower bound of the integral. In this course it will often be that $a = \infty$. The integrator can only be applied to those signals for which the integral above exists. For example, the integrator I_∞ can be applied to the signal $tu(t)$ where $u(t)$ is the step function (1.3). The output signal is

$$\int_{-\infty}^t \tau u(\tau) d\tau = \begin{cases} \int_0^t \tau d\tau = \frac{t^2}{2} & t > 0 \\ 0 & t \leq 0. \end{cases}$$

However, the integrator cannot be applied to the signal $x(t) = t$ because $\int_{-\infty}^t \tau d\tau$ does not exist.

1.4 Properties of systems

A system H is called **memoryless** if the output signal $H(x)$ at time t depends only on the input signal x at time t . For example $\frac{1}{x(t)}$ and the identity system T_0 are memoryless, but

$$x(t) + 3x(t-1) \quad \text{and} \quad \int_0^1 x(t-\tau) d\tau$$

are not. A time-shifter system T_τ with $\tau \neq 0$ is not memoryless.

A system H is **causal** if the output signal $H(x)$ at time t depends on the input signal only at times less than or equal to t . Memoryless systems such as $\frac{1}{x(t)}$ and T_0 are also causal. Time-shifters $T_\tau(x, t) = x(t - \tau)$ are causal when $\tau \geq 0$, but are not causal when $\tau < 0$. The systems

$$x(t) + 3x(t - 1) \quad \text{and} \quad \int_0^1 x(t - \tau) d\tau$$

are causal, but the systems

$$x(t) + 3x(t + 1) \quad \text{and} \quad \int_0^1 x(t + \tau) d\tau$$

are not causal.

A system H is called **bounded-input-bounded-output (BIBO) stable** or just **stable** if the output signal $H(x)$ is bounded whenever the input signal x is bounded. That is, H is stable if for every positive real number M there exists a positive real number K such that for all signals x satisfying

$$|x(t)| < M \quad \text{for all } t \in \mathbb{R},$$

it also holds that

$$|H(x, t)| < K \quad \text{for all } t \in \mathbb{R}.$$

For example, the system $x(t) + 3x(t - 1)$ is stable with $K = 4M$ since if $|x(t)| < M$ then

$$|x(t) + 3x(t - 1)| \leq |x(t)| + 3|x(t - 1)| < 4M = K.$$

The integrator I_a for any $a \in \mathbb{R}$ and differentiator D are not stable (Exercises 1.6 and 1.7).

A system H is **linear** if

$$H(ax + by) = aH(x) + bH(y)$$

for all signals x and y and all complex numbers a and b . That is, a linear system has the property: If the input consists of a weighted sum of signals, then the output consists of the same weighted sum of the responses of the system to those signals. Figure 8 indicates the linearity property using a block diagram. For example, the differentiator is linear because

$$\begin{aligned} D(ax + by, t) &= \frac{d}{dt}(ax(t) + by(t)) \\ &= a \frac{d}{dt}x(t) + b \frac{d}{dt}y(t) \\ &= aD(x, t) + bD(y, t) \end{aligned}$$

whenever both x and y are differentiable. However, the system $H(x, t) = \frac{1}{x(t)}$ is not linear because

$$H(ax + by, t) = \frac{1}{ax(t) + by(t)} \neq \frac{a}{x(t)} + \frac{b}{y(t)} = aH(x, t) + bH(y, t)$$

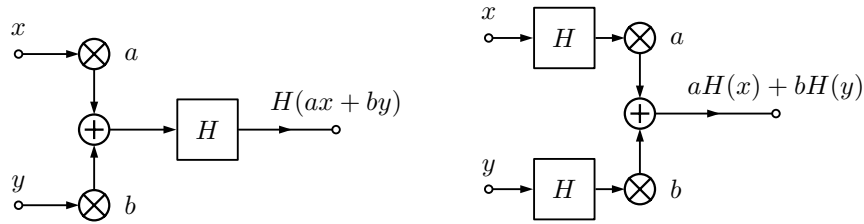

Figure 8: If H is a linear system the outputs of these two diagrams are the same signal, i.e. $H(ax + by) = aH(x) + bH(y)$.

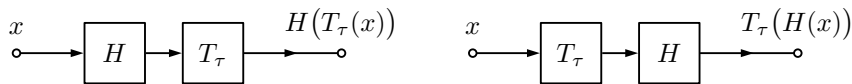

Figure 9: If H is a time-invariant system the outputs of these two diagrams are the same signal, i.e. $H(T_\tau(x)) = T_\tau(H(x))$.

in general.

The property of linearity trivially generalises to more than two signals. For example, if x_1, \dots, x_k are signals and a_1, \dots, a_k are complex numbers for some finite k , then

$$H(a_1x_1 + \dots + a_kx_k) = a_1H(x_1) + \dots + a_kH(x_k).$$

A system H is **time-invariant** if

$$H(T_\tau(x), t) = H(x, t - \tau)$$

for all signals x and all time-shifts $\tau \in \mathbb{R}$. That is, a system is time-invariant if time-shifting the input signal results in the same time-shift of the output signal. Equivalently, H is time-invariant if H commutes with the time-shifter T_τ , that is, if

$$H(T_\tau(x)) = T_\tau(H(x))$$

for all $\tau \in \mathbb{R}$ and all signals x . Figure 9 represents the property of time-invariance with a block diagram.

1.5 Exercises

- 1.1. State whether the step function $u(t)$ is bounded, periodic, absolutely integrable, an energy signal. **Solution:** The magnitude of u is less than or equal to one, so the signal is bounded. The signal is not periodic, since for any hypothesised period $T > 0$ we have $u(T) = 1$ but $u(0) = 0$. The signal is not absolutely integrable, nor an energy signal since

$$\|u\|_1 = \|u\|_2 = \int_{-\infty}^{\infty} |u(t)| dt = \int_0^{\infty} dt$$

is not finite.

1.2. Show that the signal t^2 is locally integrable, but that the signal $\frac{1}{t^2}$ is not.

Solution: For any a and b

$$\int_a^b t^2 dt = \frac{b^3}{3} - \frac{a^3}{3}$$

that exists, and so t^2 is locally integrable. Put $a = 0$ and $b > 0$ and

$$\int_0^b \frac{1}{t} dt = \log(b) - \lim_{t \rightarrow -\infty} \log(t)$$

where \log is natural logarithm. The limit about diverges, and so the integral does not exist and $\frac{1}{t}$ is not locally integrable.

1.3. Plot the signal

$$x(t) = \begin{cases} \frac{1}{t+1} & t > 0 \\ \frac{1}{t-1} & t \leq 0. \end{cases}$$

State whether it is: bounded, locally integrable, absolutely integrable, square integrable. **Solution:**

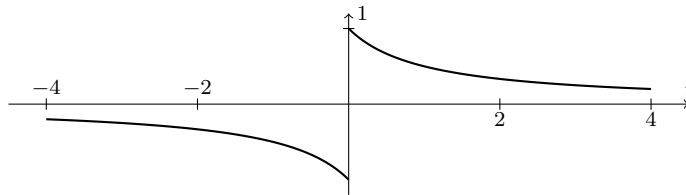

The signal is bounded since $|x(t)| < M$ for any $M > 1$. The signal is locally integrable because it is bounded, i.e., for any finite constants a and b

$$\int_a^b |x(t)| dt < \int_a^b M dt = (b - a)M < \infty.$$

The signal x is not absolutely integrable since

$$\begin{aligned} \|x\|_1 &= \int_{-\infty}^{\infty} |x(t)| dt \\ &= 2 \int_0^{\infty} \frac{1}{t+1} dt \\ &= 2 \int_1^{\infty} \frac{1}{t} dt \\ &= \log(1) + \lim_{t \rightarrow \infty} \log(t) \end{aligned}$$

and the limit diverges. The signal is square integrable since

$$\begin{aligned} \|x\|_2 &= \int_{-\infty}^{\infty} |x(t)|^2 dt \\ &= 2 \int_0^{\infty} \frac{1}{(t+1)^2} dt \\ &= 2 \int_1^{\infty} \frac{1}{t^2} dt \\ &= 1 - \lim_{t \rightarrow \infty} \frac{1}{t} = 1. \end{aligned}$$

1.4. Plot the signal

$$x(t) = \begin{cases} \frac{1}{\sqrt{t}} & 0 < t \leq 1 \\ 0 & \text{otherwise.} \end{cases}$$

Show that x is absolutely integrable, but not square integrable. **Solution:**

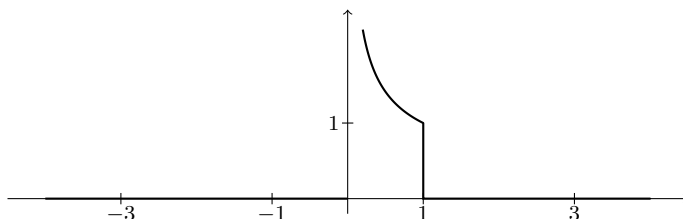

The integral

$$\|x\|_1 = \int_{-\infty}^{\infty} |x(t)| dt = \int_0^1 t^{-1/2} dt = [2\sqrt{t}]_0^1 = 2$$

and so x is absolutely integrable. The integral

$$\|x\|_2 = \int_{-\infty}^{\infty} |x(t)|^2 dt = \int_0^1 t^{-1} dt = [\log(t)]_0^1 = \log(1) - \lim_{t \rightarrow 0} \log(t) = \infty$$

and so x is not square integrable.

1.5. Compute the energy of the signal $e^{-\alpha^2 t^2}$ (Hint: use equation (1.2) on page 4 and a change of variables). **Solution:** From (1.2) we the energy of e^{-t^2} is $\sqrt{\pi}$. Now

$$\int_{-\infty}^{\infty} e^{-\alpha^2 t^2} dt = \frac{1}{\alpha} \int_{-\infty}^{\infty} e^{-\tau^2} d\tau = \frac{\sqrt{\pi}}{\alpha}$$

by the change of variables $\tau = \alpha t$.

1.6. Show that the integrator I_a for any $a \in \mathbb{R}$ is not stable. **Solution:** Put $M > 1$. The time-shifted step function $u(t+a)$ is bounded below M , i.e. $|u(t+a)| \leq 1 < M$ for all $t \in \mathbb{R}$. However, the response of the integrator I_a to $u(t+a)$ is

$$I_a(u, t) = \int_a^t dt = t - a,$$

which is not a bounded signal, that is, for every K we have $t - a > K$ whenever $t > K + a$.

1.7. Show that the differentiator system D is not stable. **Solution:** Put $M > 2$. Define the signal

$$q_a(t) = \begin{cases} 0 & 2t < -a \\ 1 + \sin\left(\frac{\pi t}{a}\right) & -a < 2t < a \\ 2 & 2t > a, \end{cases}$$

and observe that q_a is differentiable and bounded below M . The response of the differentiator D to q_a is

$$D(q_a, t) = \begin{cases} 0 & 2t < -a \\ \frac{\pi}{a} \cos\left(\frac{\pi t}{a}\right) & -a < 2t < a \\ 1 & 2t > a. \end{cases}$$

The signal p_a and the response $D(p_a)$ are plotted below for $a = \frac{1}{2}, 1$ and 2 . The response $D(p_a)$ obtains a maximum amplitude of $\frac{\pi}{a}$ at $t = 0$. So D is not bounded since for every K we can choose a such that $\frac{\pi}{a} > K$.

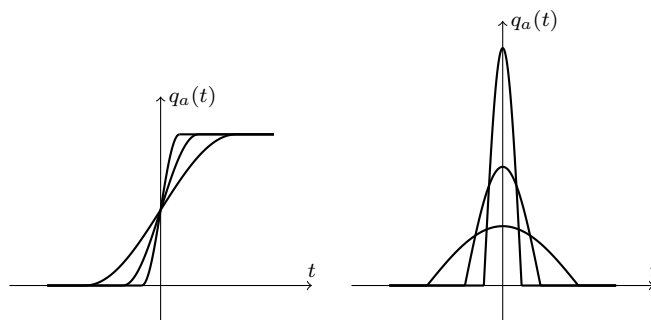

- 1.8. Show that the time-shifter T_τ is linear and time-invariant, and that the time-scaler is linear, but not time invariant **Solution:** The time shifter T_τ is time invariant since

$$T_k(T_\tau(x), t) = x(t - \tau - k) = x(t - k - \tau) = T_\tau(T_k(x), t)$$

for all signals x , that is, time shifters commute with time shifters. The time shifter is linear because

$$T_\tau(ax + by, t) = ax(t - \tau) + by(t - \tau) = aT_\tau(x, t) + bT_\tau(y, t).$$

The time-scaler $H(x, t) = x(t/\alpha)$ is linear since

$$H(ax + by, t) = ax(t/\alpha) + by(t/\alpha) = aH(x, t) + bH(y, t).$$

The system is not time invariant since

$$H(T_\tau(x), t) = T_\tau(x)(t/\alpha) = x(t/\alpha - \tau),$$

but

$$T_\tau(H(x), t) = H(x)(t - \tau) = x((t - \tau)/\alpha) = x(t/\alpha - \tau/\alpha),$$

and these signals are not equal in general. For example consider the rectangular pulse Π . With time scaling parameter $\alpha = 2$ and time shift $\tau = 1$,

$$H(T_1(x), t) = \Pi(t/2 - 1/2), \quad T_1(H(\Pi), t) = \Pi(t/2 - 1),$$

and these signals are not equal.

- 1.9. Show that the integrator I_c with c finite is linear, but not time-invariant.

Solution: The system is linear because

$$\begin{aligned} I_c(ax + by, t) &= \int_{-c}^t ax(\tau) + by(\tau) d\tau \\ &= a \int_{-c}^t x(\tau) d\tau + b \int_{-c}^t y(\tau) d\tau \\ &= aI_c(x) + bI_c(y). \end{aligned}$$

The system is not time invariant because

$$T_k(I_c(x), t) = I_c(x, t - k) = \int_{-c}^{t-k} x(\tau) d\tau$$

but

$$\begin{aligned} I_c(T_k(x), t) &= \int_{-c}^t x(\tau - k) d\tau \\ &= \int_{-c-k}^{t-k} x(\tau) d\tau \\ &= I_{c+k}(x, t - k) \\ &= T_k(I_{c+k}(x), t) \end{aligned}$$

- 1.10. Show that the integrator I_∞ is linear and time invariant. **Solution:** The system is linear because

$$\begin{aligned} I_\infty(ax + by, t) &= \int_{-\infty}^t ax(\tau) + by(\tau) d\tau \\ &= a \int_{-\infty}^t x(\tau) d\tau + b \int_{-\infty}^t y(\tau) d\tau \\ &= aI_\infty(x) + bI_\infty(y). \end{aligned}$$

The system is time invariant because

$$T_k(I_\infty(x), t) = I_\infty(x, t - k) = \int_{-\infty}^{t-k} x(\tau) d\tau,$$

and

$$I_\infty(T_k(x), t) = \int_{-\infty}^t x(\tau - k) d\tau = \int_{-\infty}^{t-k} x(\tau) d\tau.$$

- 1.11. State whether the system $H(x, t) = x(t) + 1$ is linear, time-invariant, stable. **Solution:** It is not linear because for any signal x and real number $a \neq 1$,

$$H(ax, t) = ax(t) + 1 \neq aH(x, t) = a(x(t) + 1) = ax(t) + a.$$

It is time-invariant because

$$H(T_\tau(x), t) = x(t - \tau) + 1 = H(x, t - \tau) = x(t - \tau) + 1.$$

It is stable because for any signal x with $x(t) < M$ for all $t \in \mathbb{R}$,

$$H(x, t) = x(t) + 1 < M + 1 \quad \text{for all } t \in \mathbb{R}.$$

- 1.12. State whether the system $H(x, t) = 0$ is linear, time-invariant, stable. **Solution:** It is linear because

$$H(ax + by) = 0 = aH(x) + bH(y) = 0.$$

It is time-invariant because

$$H(T_\tau(x), t) = 0 = H(x, t - \tau).$$

It is stable because for any $M > 0$,

$$H(x, t) = 0 < M \quad \text{for all } t \in \mathbb{R} \text{ and all signals } x.$$

- 1.13. State whether the system $H(x, t) = 1$ is linear, time-invariant, stable. **Solution:** It is not linear because for any signal x and real number $a \neq 1$

$$H(ax) = 1 \neq aH(x) = a.$$

It is time-invariant because

$$H(T_\tau(x), t) = 1 = H(x, t - \tau).$$

It is stable because for any $M > 1$,

$$H(x, t) = 1 < M \quad \text{for all } t \in \mathbb{R} \text{ and all signals } x.$$

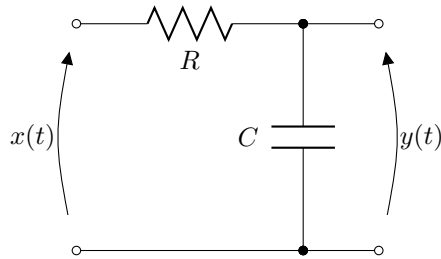

Figure 10: An electrical circuit with resistor and capacitor in series, otherwise known as an **RC circuit**.

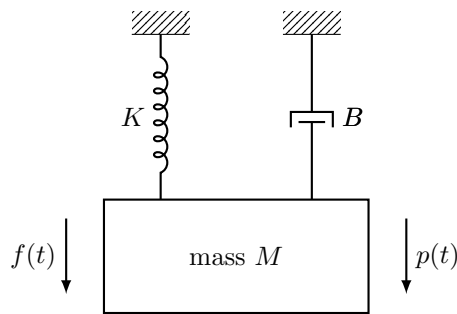

Figure 11: A mechanical mass-spring-damper system

2 Systems modelled by differential equations

Systems of significant interest in this course are those where the input signal x and output signal y are related by a linear differential equation with constant coefficients, that is, an equation of the form

$$\sum_{\ell=0}^m a_{\ell} \frac{d^{\ell}}{dt^{\ell}} x(t) = \sum_{\ell=0}^k b_{\ell} \frac{d^{\ell}}{dt^{\ell}} y(t)$$

where a_0, \dots, a_m and b_0, \dots, b_k are constant real numbers. In what follows we will use the differentiator system $D(x)$ rather than the notation $\frac{d}{dt}x(t)$ to represent differentiation of the signal x . To represent the ℓ th derivative we write $D^{\ell}(x)$. Using this notation the differential equation above is

$$\sum_{\ell=0}^m a_{\ell} D^{\ell}(x) = \sum_{\ell=0}^k b_{\ell} D^{\ell}(y). \quad (2.1)$$

Equations of this form can be used to model a large number of electrical, mechanical and other real world devices. For example, consider the resistor and capacitor (RC) circuit in Figure 10. Let the signal v_R represent the voltage over the resistor and i the current through both resistor and capacitor. The voltage

signals satisfy

$$x = y + v_R,$$

and the current satisfies both

$$v_R = Ri, \quad \text{and} \quad i = CD(y).$$

Combining these equations,

$$x = y + RCD(y) \tag{2.2}$$

that is in the form of (2.1).

As another example, consider the mass, spring and damper in Figure 11. A force represented by the signal f is externally applied to the mass, and the position of the mass is represented by the signal p . The spring exerts force $-Kp$ that is proportional to the position of the mass, and the damper exerts force $-BD(p)$ that is proportional to the velocity of the mass. The cumulative force exerted on the mass is

$$f_m = f - Kp - BD(p)$$

and by Newton's law the acceleration of the mass $D^2(p)$ satisfies

$$MD^2(p) = f_m = f - Kp - BD(p).$$

We obtain the differential equation

$$f = Kp + BD(p) + MD^2(p) \tag{2.3}$$

that is in the form of (2.1) if we put $x = f$ and $y = p$. Given p we can readily solve for the corresponding force f . As a concrete example, let the spring constant, damping constant and mass be $K = B = M = 1$. If the position satisfies $p(t) = e^{-t^2}$, then the corresponding force satisfies

$$f(t) = e^{-t^2}(4t^2 - 2t - 1).$$

Figure 12 depicts these signals.

What happens if a particular force signal f is applied to the mass? For example, say we apply the force

$$f(t) = \Pi(t - \frac{1}{2}) = \begin{cases} 1 & 0 < t \leq 1 \\ 0 & \text{otherwise.} \end{cases}$$

What is the corresponding position signal p ? We are not yet ready to answer this question, but will be later (Exercise 4.11).

In both the mechanical mass-spring-damper system in Figure 11 and the electrical RC circuit in Figure 10 we obtain a differential equation relating the input signal x with the output signal y . The equations do not specify the output signal y explicitly in terms of the input signal x , that is, they do not explicitly define a system H such $y = H(x)$. As they are, the differential equations, do

Figure 12: A solution to the mass spring damper system with $K = B = M = 1$. The position is $p(t) = e^{-t^2}$ with corresponding force $f(t) = e^{-t^2}(4t^2 - 2t - 1)$.

not provide as much information about the behaviour of the system as we would like. For example, is the system stable? The **Laplace transform**, described in Section 4, is a useful tool for answering these questions. A key property enabling the Laplace transform is that differential equations of the form (2.1) describe systems that are linear and time-invariant. We further study linear, time-invariant systems in Section 3. The remainder of this section details the construction of differential equations that model various mechanical, electrical, and electro-mechanical systems. We will use the systems constructed here as examples throughout the course.

2.1 Passive circuits

Passive electrical circuits require no sources of power other than the input signal itself. For example, the voltage divider in Figure 3 and the RC circuit in Figure 10 are passive circuits. Another common passive electrical circuit is the resistor, capacitor and inductor (RLC) circuit depicted in Figure 13. In this circuit we let the output signal y be the voltage over the resistor. Let v_C represent the voltage over the capacitor and v_L the voltage over the inductor and let i be the current. We have

$$y = Ri, \quad i = CD(v_C), \quad v_L = LD(i),$$

leading to the following relationships between y , v_C and v_L ,

$$y = RCD(v_C), \quad Rv_L = LD(y).$$

Kirchhoff's voltage law gives $x = y + v_C + v_L$ and by differentiating both sides

$$D(x) = D(y) + D(v_C) + D(v_L).$$

Substituting the equations relating y , v_C and v_L leads to

$$RCD(x) = y + RCD(y) + LCD^2(y). \quad (2.4)$$

We can similarly find equations relating the input voltage with v_C and v_L .

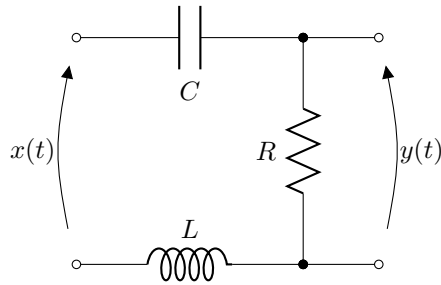

Figure 13: An electrical circuit with resistor, capacitor and inductor in series, otherwise known as an **RLC circuit**.

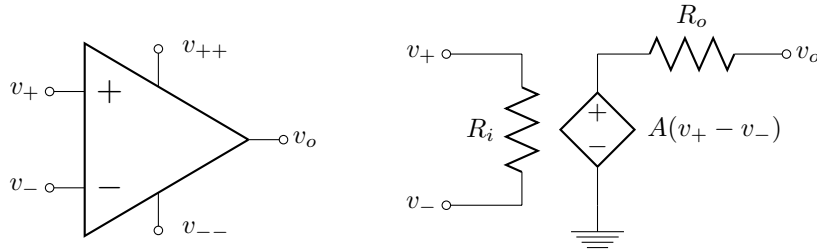

Figure 14: Left: triangular component diagram of an **operational amplifier**. The v_{++} and v_{--} connectors indicate where an external voltage source can be connected to the amplifier. These connectors will usually be omitted. Right: model for an operational amplifier including input resistance R_i , output resistance R_o , and open loop gain A . The diamond shaped component is a dependent voltage source. This model is only useful when the operational amplifier is in a negative feedback circuit.

2.2 Active circuits

Unlike passive electrical circuits, an **active circuit** requires a source of power external to the input signal. In this course active circuits will be modelled and constructed using **operational amplifiers** as depicted in Figure 14. The left hand side of Figure 14 shows a triangular circuit diagram for an operational amplifier, and the right hand side of Figure 14 shows a circuit that can be used to model the behaviour of the amplifier. The v_{++} and v_{--} connectors indicate where an external voltage source can be connected to the amplifier, and will normally not be drawn. The diamond shaped component is a dependent voltage source with voltage $A(v_+ - v_-)$ that depends on the difference between the voltage at the **non-inverting input** v_+ and the voltage at the **inverting input** v_- . The dimensionless constant A is called the **open loop gain**. Most operational amplifiers have large open loop gain A , large input resistance R_i and small output resistance R_o . As we will see, it can be convenient to consider the behaviour as $A \rightarrow \infty$, $R_i \rightarrow \infty$ and $R_o \rightarrow 0$, resulting in an **ideal operational amplifier**.

As an example, an operational amplifier configured as a **multiplier** is de-

picted in Figure 15. This circuit is an example of an operation amplifier configured with **negative feedback**, meaning that the output of the amplifier is connected (in this case by a resistor) to the inverting input. The horizontal wire at the bottom of the plot is considered to be ground (zero volts) and is connected to the negative terminal of the dependent voltage source of the operational amplifier depicted in Figure 14. An equivalent circuit for the multiplier using the model in Figure 14 is shown in Figure 16. Solving this circuit (Exercise 2.1) yields the following relationship between the input voltage signal x and the output voltage signal y ,

$$y = \frac{R_i(AR_2 + R_o)}{R_i(R_2 + R_o) + R_1(R_2 + R_i - AR_i + R_o)}x. \quad (2.5)$$

For an ideal operational amplifier we let $A \rightarrow \infty$, $R_i \rightarrow \infty$ and $R_o \rightarrow 0$. In this case terms involving the product AR_i dominate and we are left with the simpler equation

$$y = -\frac{R_2}{R_1}x. \quad (2.6)$$

Thus, assuming an ideal operational amplifier, the circuit acts as a multiplier with constant $-\frac{R_2}{R_1}$.

The equation relating x and y is much simpler for the ideal operational amplifier. Fortunately this equation can be obtained directly using the following two rules:

1. the voltage at the inverting and non-inverting inputs are equal,
2. no current flows through the inverting and non-inverting inputs.

These rules are only useful for analysing circuits with negative feedback. Let us now rederive (2.6) using these rules. Since the non-inverting input is connected to ground, the voltage at the inverting input is zero. So, the voltage over resistor R_2 is $y = R_2i$. Since no current flows through the inverting input the current through R_1 is also i and $x = -R_1i$. Combing these results, the input voltage x and the output voltage y are related by

$$y = -\frac{R_2}{R_1}x.$$

In Test 2 the inverting amplifier circuit is constructed and the relationship above is tested using a computer soundcard.

We now consider another circuit consisting of an operational amplifier, two resistors and two capacitors depicted in Figure 17. Assuming an ideal operational amplifier, the voltage at the inverting terminal is zero because the non-inverting terminal is connected to ground. Thus, the voltage over capacitor C_2 and resistor R_2 is equal to y and, by Kirchoff's current law

$$i = \frac{y}{R_2} + C_2D(y).$$

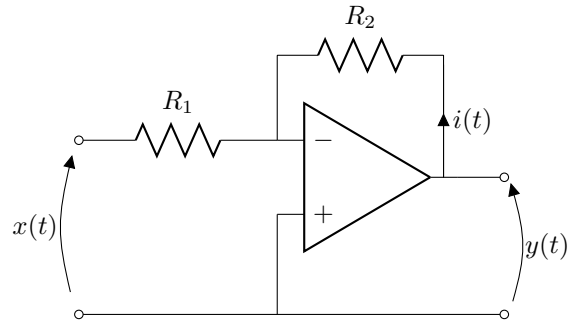

Figure 15: Inverting amplifier

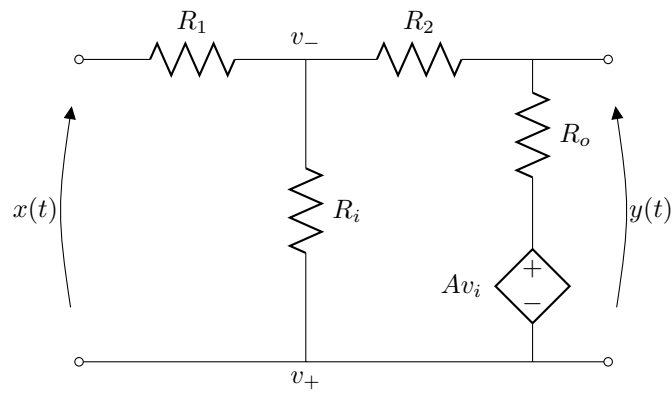

Figure 16: An equivalent circuit for the inverting amplifier from Figure 15 using the model for an operational amplifier in Figure 14. The symbol $v_i = v_+ - v_-$ is the voltage over resistor R_i .

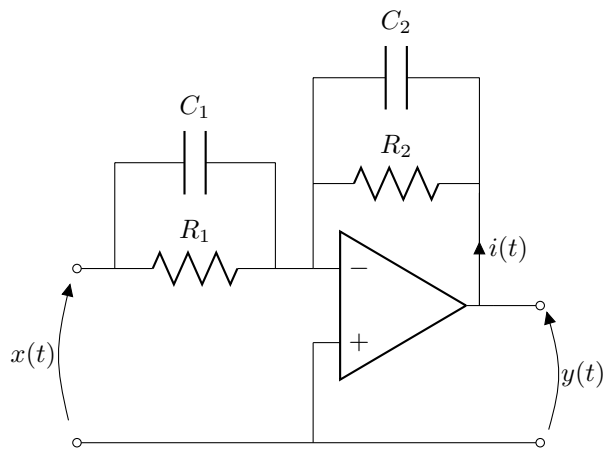

Figure 17: Operational amplifier configured with two capacitors and two resistors.

Test 2 (Inverting amplifier) In this test we construct the inverting amplifier circuit from Figure 15 with $R_2 \approx 22\text{k}\Omega$ and $R_1 \approx 12\text{k}\Omega$ that are accurate to within 5% of these values. The operational amplifier used is the Texas Instruments LM358P. Using a computer soundcard (an approximation of) the voltage signal

$$x(t) = \frac{1}{3} \sin(2\pi f_1 t) + \frac{1}{3} \sin(2\pi f_2 t)$$

with $f_1 = 100$ and $f_2 = 233$ is passed through the circuit. As in previous tests, the soundcard is used to sample the input signal x and the output signal y . Approximate reconstructions of the input signal \tilde{x} and output signal \tilde{y} are given according to (1.8), and (1.6). According to (2.4) we expect the approximate relationship

$$\tilde{y} \approx -\frac{R_2}{R_1} \tilde{x} = -\frac{11}{6} \tilde{x}.$$

Each of \tilde{y} , \tilde{x} and $-\frac{11}{6} \tilde{x}$ are plotted in Figure 18.

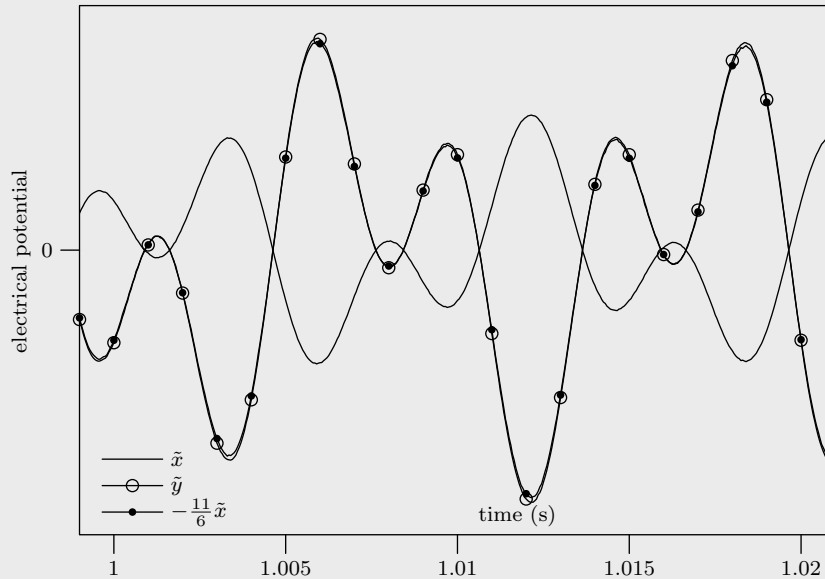

Figure 18: Plot of reconstructed input signal \tilde{x} (solid line), output signal \tilde{y} (solid line with circle) and hypothesised output signal $-\frac{11}{6} \tilde{x}$ (solid line with dot).

Similarly, since no current flows through the inverting terminal,

$$i = -\frac{x}{R_1} - C_1 D(x).$$

Combining these equations yields

$$-\frac{x}{R_1} - C_1 D(x) = \frac{y}{R_2} + C_2 D(y). \quad (2.7)$$

Observe the similarity between this equation and that for the passive RC circuit (2.2) when $R_1 = R_2$ and $C_1 = 0$ (an open circuit). In this case

$$x = -y - R_1 C_2 D(y). \quad (2.8)$$

We call this this **active RC circuit**. This circuit is tested in Test 3.

Test 3 (Active RC circuit) In this test we construct the circuit from Figure 17 with $R_1 \approx R_2 \approx 27\text{k}\Omega$ and $C_2 \approx 10\text{nF}$ accurate to within 5% of these values and $C_1 = 0$ (an open circuit). The operational amplifier used is a Texas Instruments LM358P. Using a computer soundcard (an approximation of) the voltage signal

$$x(t) = \frac{1}{3} \sin(2\pi f_1 t) + \frac{1}{3} \sin(2\pi f_2 t)$$

with $f_1 = 500$ and $f_2 = 1333$ is passed through the circuit. As in previous tests, the soundcard is used to sample the input signal x and the output signal y and approximate reconstructions \tilde{x} and \tilde{y} are given according to (1.8) and (1.6). According to (2.8) we expect the approximate relationship

$$\tilde{x} \approx -\frac{R_1}{R_2} \tilde{y} - R_1 C D(\tilde{y}) = -\tilde{y} - \frac{27}{10000} D(\tilde{y}).$$

The derivative of the sinc function is

$$D(\text{sinc}, t) = \frac{1}{\pi t^2} (\pi t \cos(\pi t) - \sin(\pi t)), \quad (2.9)$$

and so,

$$D(\tilde{y}) = D\left(\sum_{\ell=1}^L y_\ell \text{sinc}(F_s t - \ell)\right) = F_s \sum_{\ell=1}^L y_\ell D(\text{sinc}, F_s t - \ell). \quad (2.10)$$

Each of \tilde{y} , \tilde{x} and $-\tilde{y} - \frac{27}{10000} D(\tilde{y})$ are plotted in Figure 18.

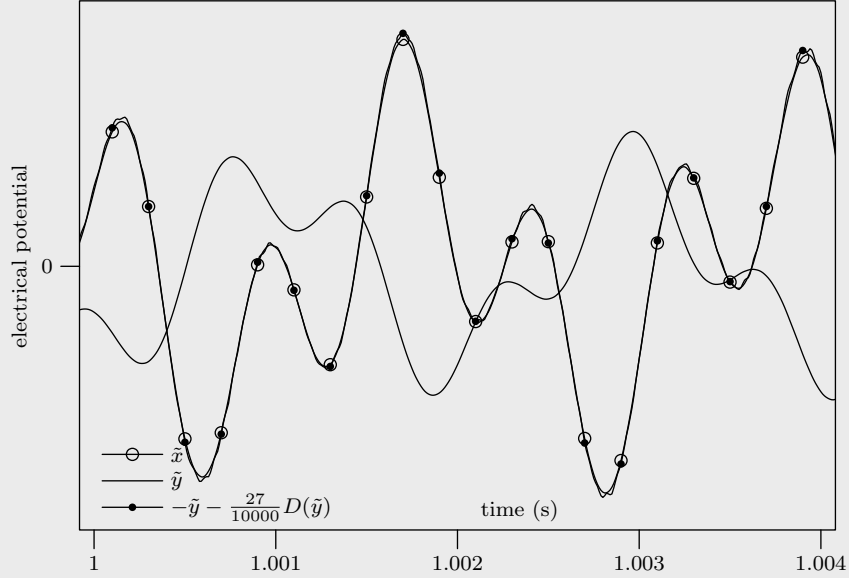

Figure 18: Plot of reconstructed input signal \tilde{x} (solid line with circle), output signal \tilde{y} (solid line), and hypothesised input signal $-\tilde{y} - \frac{27}{10000}D(\tilde{y})$ (solid line with dot).

Consider the circuit in Figure 19. Assuming an ideal operational amplifier, the input voltage x satisfies

$$-i = \frac{x}{R_1} + C_1 D(x).$$

The voltage over the capacitor C_2 is $y - R_2 i$ and so the current satisfies

$$i = C_2 D(y - R_2 i).$$

Combining these equations gives

$$-\frac{x}{R_1} - C_1 D(x) = C_2 D(y) + \frac{R_2 C_2}{R_1} D(x) + R_2 C_2 C_1 D^2(x),$$

and after rearranging,

$$D(y) = -\frac{1}{R_1 C_1} x - \left(\frac{R_2}{R_1} + \frac{C_1}{C_2} \right) D(x) - R_2 C_1 D^2(x).$$

Put

$$K_i = \frac{1}{R_1 C_2}, \quad K_p = \frac{R_2}{R_1} + \frac{C_1}{C_2}, \quad K_d = R_2 C_1$$

and now

$$D(y) = -K_i x - K_p D(x) - K_d D^2(x). \quad (2.11)$$

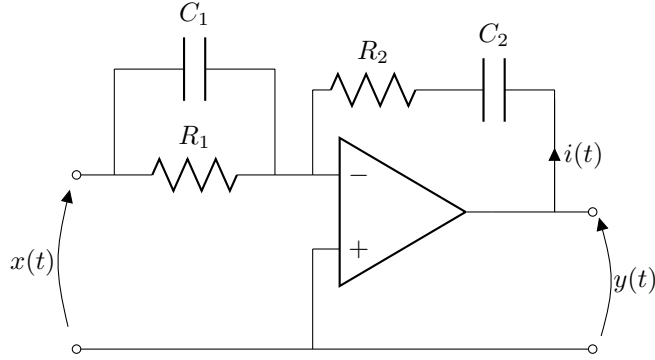

Figure 19: Operational amplifier implementing a **proportional-integral-derivative controller**.

This equation models what is called a **proportional-integral-derivative controller** or **PID controller**. The coefficients K_i, K_p and K_d are called the **integral gain, proportional gain, and derivative gain**.

The final active circuit we consider is called a **Sallen-Key** [Sallen and Key, 1955] and is depicted in Figure 20. Observe that the output of the amplifier is connected directly to the inverting input and is also connected the noninverting input by a capacitor. This circuit has both negative *and* positive feedback. It is not immediately apparent that we can use the simplifying assumptions for an ideal operational amplifier with negative feedback. However, we will do so, and will find that it works in this case.

Let v_{R1}, v_{R2}, v_{C1} , and v_{C2} be the voltages over the components R_1, R_2, C_1 , and C_2 . Kirchoff's voltage law leads to the equations

$$x = v_{R1} + v_{R2} + v_{C2}, \quad y = v_{C1} + v_{R2} + v_{C2}.$$

The voltage at the inverting and noninverting terminals is y , and so, the voltage over the capacitor C_2 is y , that is, $y = v_{C2}$. Using this, the equations above simplify to

$$x = v_{R1} + v_{R2} + y, \quad v_{C1} = -v_{R2}.$$

The current i_2 through capacitor C_2 satisfies $i_2 = C_2 D(v_{C2}) = C_2 D(y)$. Because no current flows into the inverting terminal of the amplifier the current through R_2 is also i_2 , and so $v_{R2} = R_2 i_2 = R_2 C_2 D(y)$. Substituting this into the equations above gives

$$x = v_{R1} + R_2 C_2 D(y) + y, \quad v_{C1} = -R_2 C_2 D(y). \quad (2.12)$$

Kirchoff's current law asserts that $i + i_1 = i_2$. The current i through capacitor C_1 satisfies $i = C_1 D(v_{C1}) = -R_2 C_1 C_2 D^2(y)$ and the current through resistor R_1 satisfies

$$v_{R1} = R_1 i_1 = R_1 (i_2 - i) = R_1 C_2 D(y) + R_1 R_2 C_1 C_2 D^2(y).$$

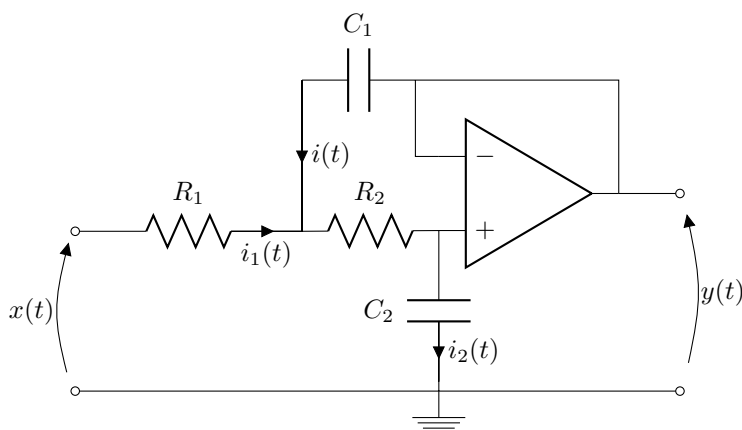

Figure 20: Operational amplifier implementing a **Sallen-Key**.

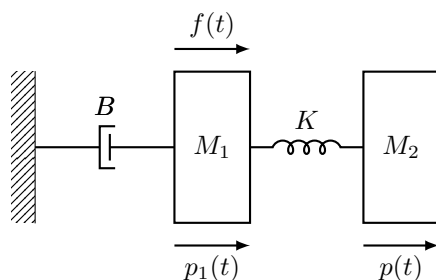

Figure 21: Two masses, a spring and a damper

Substituting this into the equation on the left of (2.12) gives

$$x = y + C_2(R_1 + R_2)D(y) + R_1R_2C_1C_2D^2(y). \quad (2.13)$$

The Sallen-Key will be useful when we consider the design on analogue electrical filters in Section 5.3.

2.3 Masses, springs and dampers

A mechanical mass, spring, damper system was described in Section 2 and Figure 11. We now consider another mechanical system involving a different configuration of masses, a spring and a damper depicted in Figure 21. A mass M_1 is connected to a wall by a damper with constant B , and to another mass M_2 by a spring with constant K . A force represented by the signal f is applied to the first mass. We will derive a differential equation relating f with the position p of the second mass. We assume that the spring applies no force (is in equilibrium) when masses are distance d apart. The forces due to the spring

satisfy

$$f_{s1} = -f_{s2} = K(p - p_1 - d)$$

where f_{s1} and f_{s2} are signals representing the force due to the spring on mass M_1 and M_2 respectively. It is convenient to define the signal $g(t) = p_1(t) + d$ so that forces due to spring satisfy the simpler equation

$$f_{s1} = -f_{s2} = K(p - g).$$

The only force applied to M_2 is by the spring and so, by Newton's law, the acceleration of M_2 satisfies

$$M_2 D^2(p) = f_{s2}.$$

Substituting this into the previous equation gives a differential equation relating g and p ,

$$Kg = Kp + M_2 D^2(p). \quad (2.14)$$

The force applied by the damper on mass M_1 is given by the signal

$$f_d = -BD(p_1) = -BD(g)$$

where the replacement of p_1 by g is justified because differentiation will remove the constant d . The cumulative force on M_1 is given by the signal

$$\begin{aligned} f_1 &= f + f_d + f_{s1} \\ &= f - Kg + Kp - BD(g), \end{aligned} \quad (2.15)$$

and by Newton's law the acceleration of M_1 satisfies

$$M_1 D^2(p_1) = M_1 D^2(g) = f_1.$$

Substituting this into (2.15) and using (2.14) we obtain a fourth order differential equation relating p and f ,

$$f = BD(p) + (M_1 + M_2)D^2(p) - \frac{BM_2}{K}D^3(p) + \frac{M_1M_2}{K}D^4(p). \quad (2.16)$$

Given the position of the second mass p we can readily solve for the corresponding force f and position of the first mass p_1 . For example, if the constants $B = K = 1$ and $M_1 = M_2 = \frac{1}{2}$ and $d = \frac{5}{2}$, and if the position of the second mass satisfies

$$p(t) = e^{-t^2}$$

then, by application of (2.16) and (2.14),

$$f(t) = e^{-t^2}(1 - 8t - 8t^2 + 4t^3 + 4t^4), \quad \text{and} \quad p_1(t) = 2e^{-t^2}t^2 - \frac{5}{2}.$$

This solution is plotted in Figure 22.

Figure 22: Solution of the system describing two masses with a spring and damper where $B = K = 1$ and $M_1 = M_2 = \frac{1}{2}$ and the position of the second mass is $p(t) = e^{-t^2}$.

2.4 Direct current motors

Direct current (DC) motors convert electrical energy, in the form of a voltage, into rotary kinetic energy [Nise, 2007, page 76]. We derive a differential equation relating the input voltage v to the angular position of the motor θ . Figure 23 depicts the components of a DC motor.

The voltages over the resistor and inductor satisfy

$$v_R = Ri, \quad v_L = LD(i),$$

and the motion of the motor induces a voltage called the back electromotive force (EMF),

$$v_b = K_b D(\theta)$$

that we model as being proportional to the angular velocity of the motor. The input voltage now satisfies

$$v = v_R + v_L + v_b = Ri + LD(i) + K_b D(\theta).$$

The torque τ applied by the motor is modelled as being proportional to the current i ,

$$\tau = K_\tau i.$$

A load with inertia J is attached to the motor. Two forces are assumed to act on the load, the torque τ applied by the current, and a torque $\tau_d = -BD(\theta)$

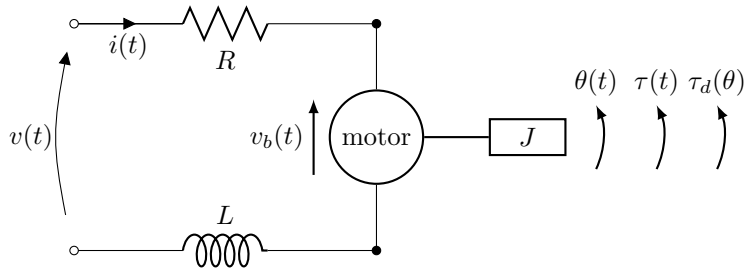

Figure 23: Diagram for a rotary direct current (DC) motor

modelling a damper that acts proportionally against the angular velocity of the motor. By Newton's law, the angular acceleration of the load satisfies

$$JD^2(\theta) = \tau + \tau_d = K_\tau i - BD(\theta).$$

Combining these equations we obtain the 3rd order differential equation

$$v = \left(\frac{RB}{K_\tau} + K_b \right) D(\theta) + \frac{RJ + LB}{K_\tau} D^2(\theta) + \frac{LJ}{K_\tau} D^3(\theta)$$

relating voltage and motor position. In many DC motors the inductance L is small and can be ignored, leaving the simpler second order equation

$$v = \left(\frac{RB}{K_\tau} + K_b \right) D(\theta) + \frac{RJ}{K_\tau} D^2(\theta). \quad (2.17)$$

Given the position signal θ we can find the corresponding voltage signal v . For example, put the constants $K_b = K_\tau = B = R = J = 1$ and assume that

$$\theta(t) = 2\pi(1 + \operatorname{erf}(t))$$

where $\operatorname{erf}(t) = \frac{2}{\pi} \int_{-\infty}^t e^{-\tau^2} d\tau$ is the **error function**. The corresponding angular velocity $D(\theta)$ and voltage v satisfy

$$D(\theta, t) = 4\sqrt{\pi}e^{-t^2}, \quad v(t) = 8\sqrt{\pi}e^{-t^2}(1 - t).$$

These signals are depicted in Figure 24. This voltage signal is sufficient to make the motor perform two revolutions and then come to rest.

2.5 Exercises

- Analyse the inverting amplifier circuit in Figure 16 to obtain the relationship between input voltage x and output voltage y given by (2.5). You may wish to use a symbolic programming language (for example Sage, Mathematica, or Maple). **Solution:** Let v_i , v_o , v_1 and v_2 be the voltages over the input resistor R_i , the output resistor R_o , and resistors R_1 and R_2 respectively.

Figure 24: Voltage and corresponding angle for a DC motor with constants $K_b = K_\tau = B = R = J = 1$.

Observe that $v_+ - v_i = v_i$ and so the voltage over the dependent source is Av_i . The voltages satisfy,

$$\begin{aligned}x &= v_1 + v_i \\y &= v_i - v_2 \\y &= v_o + Av_i\end{aligned}$$

The currents into the 3 way connection between R_i, R_1 and R_2 sum to zero, and so

$$\frac{v_1}{R_1} = \frac{v_i}{R_i} + \frac{v_2}{R_2}$$

by Ohm's law, the direction of current moving from positive to negative voltage. Finally the currents through R_o and R_2 are the same, and so

$$\frac{v_o}{R_o} = \frac{v_2}{R_2}.$$

We now have 5 linearly independent equations for the six unknowns v_1, v_2, v_o, v_i, x, y . We can use these to find an equation that describes y in terms of x . The Mathematica command

```
Simplify[Solve[{x == v1 + vi,
y == vo + A*vi,
y == vi - v2,
v1/r1 == vi/vi + v2/r2,
vo/ro == v2/r2,
r1 > 0, r2 > 0, ro > 0, ri > 0, A > 0},
{y, vi, vo, v2, v1}, Reals]]
```

readily obtains

$$y = \frac{R_i(AR_2 + R_o)}{R_i(R_2 + R_o) + R_1(R_2 + R_i - AR_i + R_o)}x.$$

3 Linear time-invariant systems

Throughout this section we let H be a linear time-invariant system.

3.1 Convolution, regular systems and the delta “function”

A large number of linear time-invariant systems can be represented by a signal called the **impulse response**. The impulse response of a system H is a signal h such that

$$H(x, t) = \int_{-\infty}^{\infty} h(\tau)x(t - \tau)d\tau,$$

that is, the response of H to input signal x can be represented as an integral equation involving x and the impulse response h . The integral is called a **convolution** and appears so often that a special notation is used for it

$$h * x = \int_{-\infty}^{\infty} h(\tau)x(t - \tau)d\tau.$$

Those systems that have an impulse response we call **regular systems**¹. Observe that regular systems are linear because

$$\begin{aligned} H(ax + by) &= h * (ax + by) \\ &= \int_{-\infty}^{\infty} h(\tau)(ax(t - \tau) + by(t - \tau))d\tau \\ &= a \int_{-\infty}^{\infty} h(\tau)x(t - \tau)d\tau + b \int_{-\infty}^{\infty} h(\tau)y(t - \tau)d\tau \quad (3.1) \\ &= a(h * x) + b(h * y) \\ &= aH(x) + bH(y). \end{aligned}$$

The above equations show that convolution commutes with scalar multiplication and distributes with addition, that is

$$h * (ax + by) = a(h * x) + b(h * y).$$

Regular systems are also time-invariant because

$$\begin{aligned} T_{\kappa}(H(x)) &= H(x, t - \kappa) \\ &= \int_{-\infty}^{\infty} h(\tau)x(t - \kappa - \tau)d\tau \\ &= \int_{-\infty}^{\infty} h(\tau)T_{\kappa}(x, t - \tau)d\tau \\ &= H(T_{\kappa}(x)). \end{aligned}$$

¹The name **regular system** is motivated by the term **regular distribution** [Zemanian, 1965]

We can define the impulse response of a regular system H in the following way. First define the signal

$$p_\gamma(t) = \begin{cases} \gamma, & 0 < t \leq \frac{1}{\gamma} \\ 0, & \text{otherwise} \end{cases}$$

that is a rectangular shaped pulse of height γ and width $\frac{1}{\gamma}$. The signal p_γ is plotted in Figure 25 for $\gamma = \frac{1}{2}, 1, 2, 5$. As γ increases the pulse gets thinner and higher so as to keep the area under p_γ equal to one. Consider the response of the regular system H to the signal p_γ ,

$$\begin{aligned} H(p_\gamma)(t) &= (h * p_\gamma)(t) \\ &= \int_{-\infty}^{\infty} h(\tau)p_\gamma(t - \tau)d\tau \\ &= \gamma \int_{t-1/\gamma}^t h(\tau)d\tau, \end{aligned}$$

because $p_\gamma(t - \tau) = 1$ when $\tau \in (t - \frac{1}{\gamma}, t]$ and zero otherwise. Taking limits as $\gamma \rightarrow \infty$,

$$\lim_{\gamma \rightarrow \infty} H(p_\gamma)(t) = \lim_{\gamma \rightarrow \infty} \gamma \int_{t-1/\gamma}^t h(\tau)d\tau = h(t) \text{ a.e.}$$

Thus, the impulse response of a regular system H is defined as the limit

$$h = \lim_{\gamma \rightarrow \infty} H(p_\gamma).$$

The limit exists when H is regular. If this limit does not exist, the system is not regular and does not have an impulse response.

As an example, consider the integrator system

$$I_\infty(x, t) = \int_{-\infty}^t x(\tau)d\tau \tag{3.2}$$

described in Section 1.3. This systems response to p_γ is

$$I_\infty(p_\gamma, t) = \int_{-\infty}^t p_\gamma(\tau)d\tau = \begin{cases} 0, & t \leq 0 \\ \gamma t, & 0 < t \leq \frac{1}{\gamma} \\ 1, & t > \frac{1}{\gamma}. \end{cases}$$

The response is plotted in Figure 25. Taking the limit as $\gamma \rightarrow \infty$ we find that the impulse response of the integrator is the step function

$$u(t) = \lim_{\gamma \rightarrow \infty} H(p_\gamma) = \begin{cases} 0 & t \leq 0 \\ 1 & t > 0. \end{cases} \tag{3.3}$$

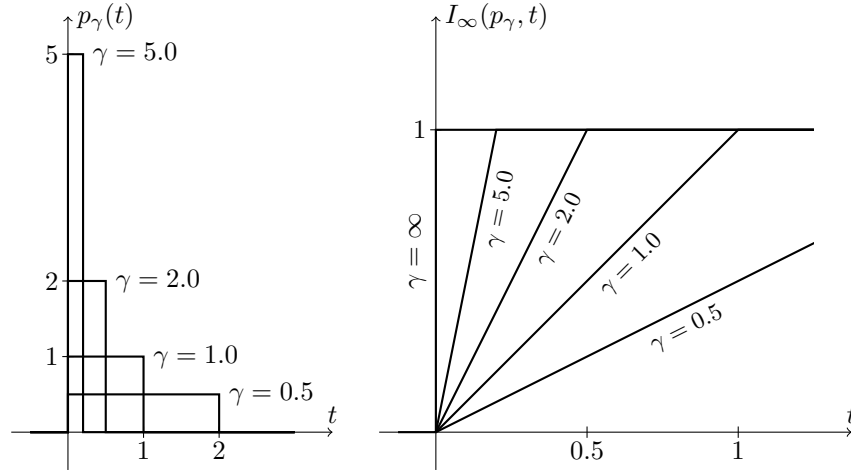

Figure 25: The rectangular shaped pulse p_γ for $\gamma = 0.5, 1, 2, 5$ and the response of the integrator (3.2) to p_γ for $\gamma = 0.5, 1, 2, 5, \infty$.

Some important systems do not have an impulse response. For example, the identity system T_0 does not because

$$\lim_{\gamma \rightarrow \infty} T_0(p_\gamma) = \lim_{\gamma \rightarrow \infty} p_\gamma$$

does not exist. Similarly, all the time shifters T_τ do not have impulse responses. However, it is notationally useful to pretend that T_0 *does* have an impulse response and we denote it by the symbol δ called the **delta function**. The idea is to assign δ the property

$$\int_{-\infty}^{\infty} x(t)\delta(t)dt = x(0)$$

so that convolution of x and δ is

$$\delta * x = \int_{-\infty}^{\infty} \delta(\tau)x(t - \tau)d\tau = x(t) = T_0(x, t).$$

We now treat δ as if it were a signal. So $\delta(t - \tau)$ will represent the impulse response of the time shifter T_τ because

$$\begin{aligned} T_\tau(x) &= \delta(t - \tau) * x \\ &= \int_{-\infty}^{\infty} \delta(\kappa - \tau)x(t - \kappa)d\kappa \\ &= \int_{-\infty}^{\infty} \delta(k)x(t - \tau - k)dk \quad (\text{change variable } k = \kappa - \tau) \\ &= x(t - \tau). \end{aligned}$$

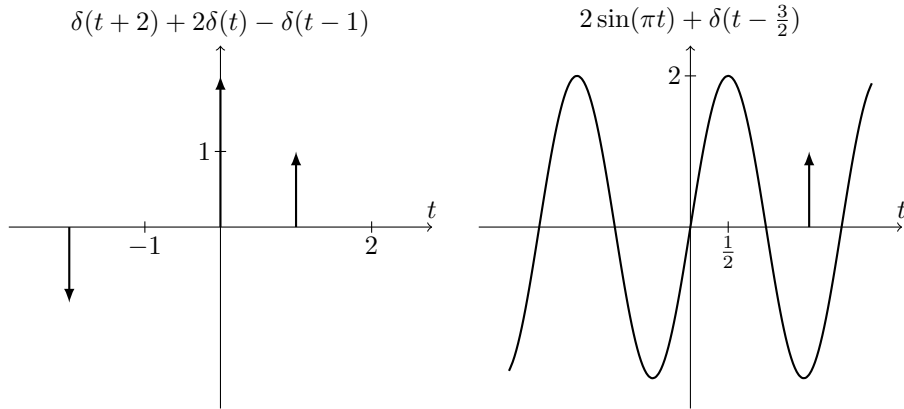

Figure 26: Plot of the signal $\delta(t+2) + 2\delta(t) - \delta(t-1)$ (left) and the signal $2\sin(\pi t) + \delta(t - \frac{3}{2})$ (right).

It is common to plot $a\delta(t - \tau)$ using an arrow of height a at $t = \tau$ as indicated in Figure 26. It is important to realise that δ is not actually a signal. It is not a function. However, it can be convenient to treat δ as if it were a function. The manipulations in the last set of equations, such as the change of variables, are not formally justified, but they do lead to the desired result $T_\tau(x) = x(t - \tau)$ in this case. In general, there is no guarantee that mechanical mathematical manipulations involving δ will lead to sensible results.

The only other non regular systems that we have use of are differentiators D^k , and it is convenient to define a similar notation for pretending that these systems have an impulse response. In this case we use the symbol δ^k and assign it the property

$$\int_{-\infty}^{\infty} x(t)\delta^k(t)dt = D^k(x, 0),$$

so that convolution of x and δ is

$$\delta^k * x = \int_{-\infty}^{\infty} \delta^k(\tau)x(t - \tau)d\tau = D^k(x, t).$$

As with the delta function the symbol δ^k must be treated with care. This notation can be useful, but purely formal manipulations with δ^k may not lead to sensible results in general.

The impulse response h immediately yields some properties of the corresponding system H . For example, if $h(t) = 0$ for all $t < 0$, then H is causal because

$$H(x, t) = h * x = \int_{-\infty}^{\infty} h(\tau)x(t - \tau)d\tau = \int_0^{\infty} h(\tau)x(t - \tau)d\tau$$

only depends on values of x at times less than t , i.e., only times $t - \tau$ with $\tau > 0$. The system H is stable if and only if h is absolutely integrable (Exercise 3.3).

Another important signal is the **step response** of a system that is defined as the response of the system to the step function $u(t)$. For example, the step response of the time shifter T_τ is the time shifted step function $T_\tau(u, t) = u(t - \tau)$. The step response of the integrator I_∞ is

$$I_\infty(u, t) = \int_{-\infty}^t u(t) dt = \begin{cases} \int_0^t dt = t & t > 0 \\ 0 & t \leq 0. \end{cases}$$

This signal is often called the **ramp function**. Not all systems have a step response. For example, the system with impulse response $u(-t)$ does not because the convolution of the step $u(t)$ and its reflection $u(-t)$ does not exist. If a system H has both an impulse response h and a step response $H(u)$, then these two signals are related. To see this, observe that the step response is

$$H(u) = h * u = \int_{-\infty}^{\infty} h(\tau)u(t - \tau)d\tau = \int_{-\infty}^t h(\tau)d\tau = I_\infty(h, t). \quad (3.4)$$

Thus, the step response can be obtained by applying the integrator I_∞ to the impulse response.

3.2 Properties of convolution

The convolution $x * y$ of two signals x and y does not always exist. For example, if $x = u(t)$ and $y = u(-t)$, then

$$x * y = \int_{-\infty}^{\infty} u(\tau)u(\tau - t)d\tau = \int_t^{\infty} d\tau,$$

which is not finite for any t . On the other hand, if $x = y = u(t)$, then

$$x * y = \int_{-\infty}^{\infty} u(\tau)u(t - \tau)d\tau = \begin{cases} \int_0^t dt = t & t > 0 \\ 0 & t \leq 0, \end{cases}$$

which exists for all t .

We have already shown in (3.1) that convolution commutes with scalar multiplication and is distributive with addition, that is, for signals x, y, w and complex numbers a, b ,

$$a(x * w) + b(y * w) = (ax + by) * w.$$

Convolution is commutative, that is, $x * y = y * x$ whenever these convolutions exist. To see this, write

$$\begin{aligned} x * y &= \int_{-\infty}^{\infty} x(\tau)y(t - \tau)d\tau \\ &= \int_{-\infty}^{\infty} x(t - \kappa)y(\kappa)d\kappa \quad (\text{change variable } \kappa = t - \tau) \\ &= y * x. \end{aligned}$$

Convolution is also associative, that is, for signals x, y, z ,

$$(x * y) * z = x * (y * z). \quad (\text{see Exercise 3.2})$$

By combining the associative and commutative properties we find that the order in which the convolutions in $x * y * z$ are performed does not matter, that is

$$x * y * z = y * z * x = z * x * y = y * x * z = x * z * y = z * y * x$$

provided that all the convolutions involved exist. More generally, the order in which any sequence of convolutions is performed does not change the final result.

3.3 Linear combining and composition

Let H_1 and H_2 be linear time-invariant systems and let H be the system

$$H(x) = cH_1(x) + dH_2(x), \quad c, d \in \mathbb{R}$$

formed by a linear combination of H_1 and H_2 . The system H is linear because for signals x, y and complex numbers a, b ,

$$\begin{aligned} H(ax + by) &= cH_1(ax + by) + dH_2(ax + by) \\ &= acH_1(x) + bcH_1(y) + adH_2(x) + bdH_2(y) \quad (\text{linearity } H_1, H_2) \\ &= a(cH_1(x) + dH_2(x)) + b(cH_1(y) + dH_2(y)) \\ &= aH(x) + bH(y). \end{aligned}$$

The system is also time-invariant because

$$\begin{aligned} H(T_\tau(x)) &= cH_1(T_\tau(x)) + dH_2(T_\tau(x)) \\ &= cT_\tau(H_1(x)) + dT_\tau(H_2(x)) \quad (\text{time-invariance } H_1, H_2) \\ &= T_\tau(cH_1(x) + dH_2(x)) \quad (\text{linearity } T_\tau) \\ &= T_\tau(H(x)). \end{aligned}$$

So, we can construct linear time-invariant systems by **linearly combining** (adding and multiplying by constants) other linear time-invariant systems. If H_1 and H_2 are regular systems this linear combining property can be expressed using their impulse responses h_1 and h_2 . We have

$$\begin{aligned} H(x) &= aH_1(x) + bH_2(x) \\ &= ah_1 * x + bh_2 * x \\ &= (ah_1 + bh_2) * x \quad (\text{distributivity of convolution}) \\ &= h * x, \end{aligned}$$

and so, H is a regular system with impulse response $h = ah_1 + bh_2$.

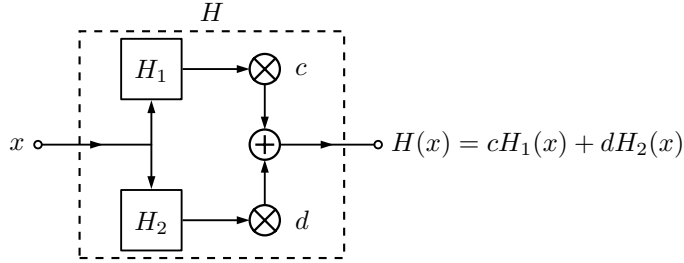

Figure 27: Block diagram depicting the linear combining property of linear time-invariant systems. The system $cH_1(x) + dH_2(x)$ can be expressed as a single linear time-invariant system $H(x)$.

Another way to construct linear time-invariant systems is by **composition**. Let H_1 and H_2 be linear time-invariant systems and let

$$H(x) = H_2(H_1(x)),$$

that is, H first applies the system H_1 and then applies the system H_2 . The composition $H_2(H_1(x))$ only applies to those signals x in the domain of H_1 and such that the signal $H_1(x)$ is in the domain of H_2 . The system H is linear because, for signals x, y and complex numbers a, b ,

$$\begin{aligned} H(ax + by) &= H_2(H_1(ax + by)) \\ &= H_2(aH_1(x) + bH_1(y)) && \text{(linearity } H_1) \\ &= aH_2(H_1(x)) + bH_2(H_1(y)) && \text{(linearity } H_2) \\ &= aH(x) + bH(y). \end{aligned}$$

The system is also time-invariant because

$$\begin{aligned} H(T_\tau(x)) &= H_2(H_1(T_\tau(x))) \\ &= H_2(T_\tau(H_1(x))) && \text{(time-invariance } H_1) \\ &= T_\tau(H_2(H_1(x))) && \text{(time-invariance } H_2) \\ &= T_\tau(H(x)). \end{aligned}$$

If H_1 and H_2 are regular systems the composition property can be expressed using their impulse responses h_1 and h_2 . It follows that

$$\begin{aligned} H(x) &= H_2(H_1(x)) \\ &= h_2 * (h_1 * x) \\ &= (h_2 * h_1) * x && \text{(associativity of convolution)} \\ &= h * x, \end{aligned}$$

and so, H is a regular system with impulse response $h = h_2 * h_1$.

A wide variety of linear time-invariant systems can now be constructed by linearly combining and composing simpler systems.

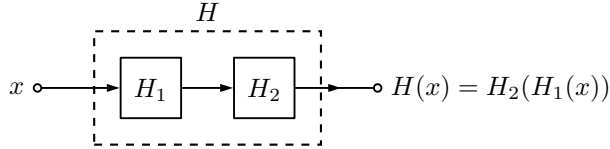

Figure 28: Block diagram depicting the composition property of linear time-invariant systems. The system $H_2(H_1(x))$ can be expressed as a single linear time-invariant system $H(x)$.

3.4 Eigenfunctions and the transfer function

Let $s = \sigma + j\omega \in \mathbb{C}$. Complex exponential signals of the form

$$e^{st} = e^{\sigma t} e^{j\omega t} = e^{\sigma t} (\cos(\omega t) + j \sin(\omega t))$$

play an important role in the study of linear time-invariant systems. The real and imaginary parts of the signal $e^{(\sigma + j\pi)t}$ with $\sigma = -\frac{1}{10}, 0, \frac{1}{10}$ are plotted in Figure 29. The signal is oscillatory when $\omega \neq 0$. The signal converges to zero as $t \rightarrow \infty$ when $\sigma < 0$ and diverges as $t \rightarrow \infty$ when $\sigma > 0$.

Let H be a linear time-invariant system and let $y = H(e^{st})$ be the response of H to the exponential signal e^{st} . Consider the response of H to the time-shifted signal $e^{s(t+\tau)}$ for $\tau \in \mathbb{R}$. By time-invariance

$$H(e^{s(t+\tau)}, t) = H(e^{st}, t + \tau) = y(t + \tau) \quad \text{for all } t, \tau \in \mathbb{R},$$

and by linearity

$$H(e^{s(t+\tau)}, t) = e^{s\tau} H(e^{st}, t) = e^{s\tau} y(t) \quad \text{for all } t, \tau \in \mathbb{R}.$$

Combining these equations we obtain

$$y(t + \tau) = e^{s\tau} y(t) \quad \text{for all } t, \tau \in \mathbb{R}.$$

This equation is satisfied by signals of the form $y(t) = \lambda e^{st}$ where λ is a complex number. That is, the response of H to an exponential signal e^{st} is the same signal e^{st} multiplied by some constant complex number λ . Due to this property exponential signals are called **eigenfunctions** of linear time-invariant systems. The constant λ does not depend on t , but it does usually depend on the complex number s and the system H . To highlight this dependence on H and s we write $\lambda(H, s)$ or $\lambda(H)(s)$. Considered as a function of s , $\lambda(H, s)$ is called the **transfer function** of the system H . Thus, the transfer function satisfies

$$H(e^{st}) = \lambda(H, s)e^{s\tau}. \quad (3.5)$$

We can use these eigenfunctions to better understand the properties of systems modelled by differential equations, such as those in Section 2. As an example, consider the active electrical circuit from Figure 17. In the case that

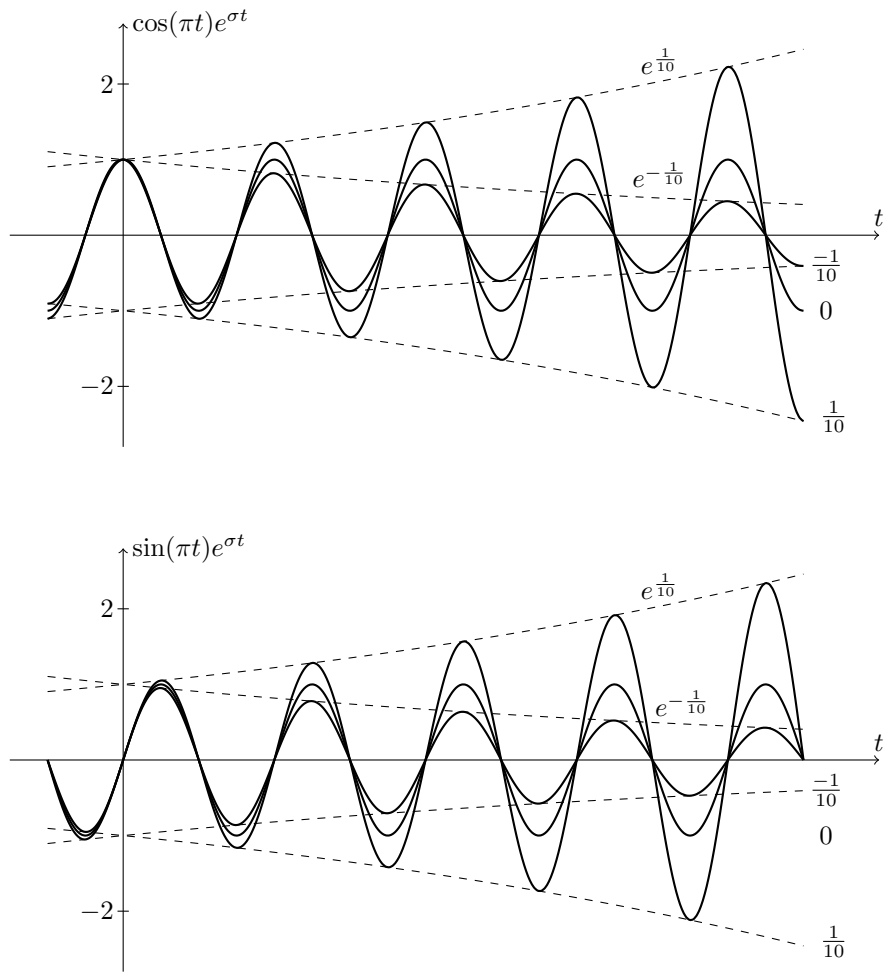

Figure 29: The function $\cos(\pi t)e^{\sigma t}$ (top) and $\sin(\pi t)e^{\sigma t}$ (bottom) for $\sigma = -\frac{1}{10}, 0, \frac{1}{10}$.

the resistors $R_1 = R_2$, and the capacitor $C_1 = 0$ (an open circuit) the differential equation relating the input voltage x and output voltage y is

$$x = -y - R_1 C_2 D(y).$$

We called this the **active RC** circuit. To simplify notation put $R = R_1$ and $C = C_2$ so that $x = -y - RCD(y)$. Observe what occurs when $y = ce^{st}$ is a complex exponential signal with $c \in \mathbb{C}$. We have

$$x = -ce^{st} - cRCse^{st} = -(1 + RCs)ce^{st} = -(1 + RCs)y,$$

and so, x is also a complex exponential signal. We immediately obtain the relationship

$$y = -\frac{1}{1 + RCs}x,$$

that holds whenever y (or equivalently x) is of the form ce^{st} with $c \in \mathbb{C}$. Let H be a system that maps the input voltage x to the output voltage y , i.e., H is a system that describes the active RC circuit. Putting $x = e^{st}$ in the equation above, we find that

$$y = H(x) = H(e^{st}) = -\frac{1}{1 + RCs}e^{st},$$

and so, the transfer function of the system H describing the active RC circuit is

$$\lambda(H, s) = -\frac{1}{1 + RCs}. \quad (3.6)$$

3.5 The spectrum

It is often of interest to focus on the transfer function when s is purely imaginary, that is, when $s = j\omega$. In this case the complex exponential signal takes the form

$$e^{j\omega t} = \cos(\omega t) + j \sin(\omega t).$$

This signal is oscillatory when $\omega \neq 0$ and does not decay or explode as $|t| \rightarrow \infty$. The function

$$\Lambda(H, f) = \lambda(H, j2\pi f)$$

is called the **spectrum** of the system H . It follows from (3.5) that the response of the system to the complex exponential signal $e^{j2\pi ft}$ satisfies

$$H(e^{j2\pi ft}) = \lambda(H, j2\pi f)e^{j2\pi ft} = \Lambda(H, f)e^{j2\pi ft}, \quad f \in \mathbb{R}.$$

It is of interest to consider the **magnitude spectrum** $|\Lambda(H, f)|$ and the **phase spectrum** $\angle \Lambda(H, f)$ separately. The notation \angle denotes the **argument** (or **phase**) of a complex number. We have,

$$\Lambda(H, f) = |\Lambda(H, f)| e^{j\angle \Lambda(H, f)},$$

and correspondingly,

$$H(e^{j2\pi ft}) = |\Lambda(H, f)| e^{j(2\pi ft + \angle\Lambda(H, f))}.$$

By taking real and imaginary parts we obtain the pair of real valued solutions

$$\begin{aligned} H(\cos(2\pi ft)) &= |\Lambda(H, f)| \cos(2\pi ft + \angle\Lambda(H, f)), \\ H(\sin(2\pi ft)) &= |\Lambda(H, f)| \sin(2\pi ft + \angle\Lambda(H, f)). \end{aligned} \quad (3.7)$$

Consider again the active RC circuit with H the system mapping the input voltage x to the output voltage y . According to (3.6) the spectrum of H is

$$\Lambda(H, f) = -\frac{1}{1 + 2\pi RC f j}. \quad (3.8)$$

The magnitude and phase spectrum is

$$|\Lambda(H, f)| = (1 + 4\pi^2 R^2 C^2 f^2)^{-\frac{1}{2}}, \quad \angle\Lambda(H, f) = \text{atan}(2\pi RC f) + \pi.$$

The magnitude and phase spectrum are plotted in Figure 30. Observe from the plot of the magnitude spectrum that a low frequency sinusoidal signal, say 100Hz or less, input to the RC circuit results in a sinusoidal output signal with the same frequency and approximately the same amplitude. However, a high frequency sinusoidal signal, say greater than 1000Hz, input to the RC circuit results in a sinusoidal output signal with the same frequency, but small amplitude. For this reason RC circuits are called **low pass filters**.

Test 4 (Spectrum of the active RC circuit) We test the hypothesis that the active RC circuit satisfies (3.7). To do this sinusoidal signals at varying frequencies of the form

$$x_k(t) = \sin(2\pi f_k t), \quad f_k = 110 \times 2^{k/2}, \quad k = 0, 1, \dots, 12$$

are input to the active RC circuit constructed as in Test 3 with $R = R_1 = 27\text{k}\Omega$ and $C = C_2 = 10\text{nF}$. In view of (3.7) the expected output signals are of the form

$$y_k(t) = |\Lambda(H, f_k)| \sin(2\pi f_k t + \angle\Lambda(H, f_k)), \quad k = 0, 1, \dots, 12.$$

This equality can also be shown directly using the differential equation for the active RC circuit. For any positive integer M the energy of the periodic transmitted signal x_k over any interval of length $T = M/f_k$ (an interval containing M periods) is

$$\text{energy}(x_k) = \int_0^T \sin^2(2\pi f_k t) dt = \frac{1}{2} \int_0^T 1 - \cos(4\pi f_k t) dt = \frac{T}{2} = \frac{M}{2f_k}.$$

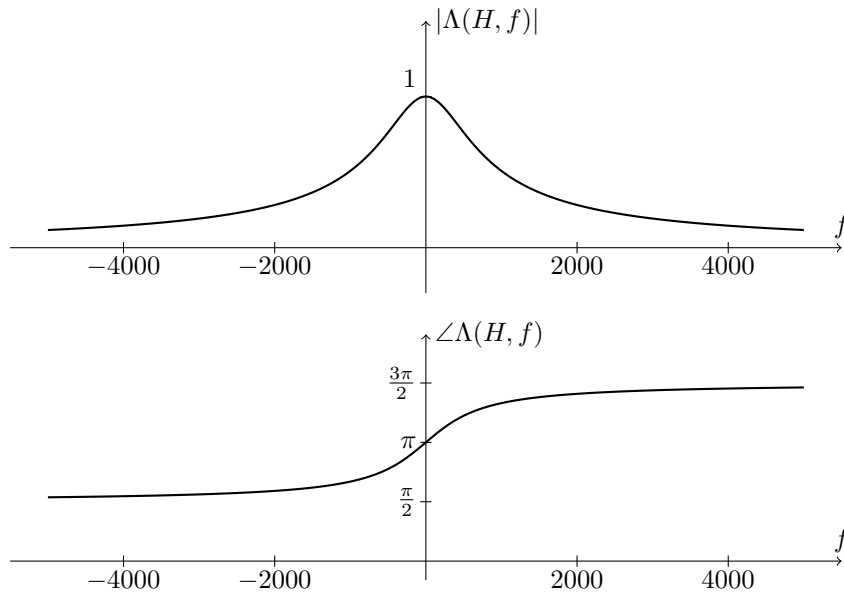

Figure 30: Magnitude spectrum (top) and phase spectrum (bottom) of the active RC circuit with $R = 27 \times 10^3$ and $C = 10 \times 10^{-9}$.

The energy of the output signal y_k over the same interval is

$$\text{energy}(y_k) = |\Lambda(H, f_k)|^2 \text{energy}(x_k) = \frac{\text{energy}(x_k)}{1 + 4\pi^2 R^2 C^2 f_k^2}. \quad (3.9)$$

We see that the square of the magnitude spectrum relates the energy of the input and output signals. We test this relationship.

Using the soundcard the signals x_k for each $k = 0, \dots, 21$ are input to the circuit. Reconstructions of the input signal \tilde{x}_k and the output signal \tilde{y}_k are constructed from samples $x_{k,1}, \dots, x_{k,L}$ and $y_{k,1}, \dots, y_{k,L}$ in a similar manner to (1.8) and (1.6) where L is the number of samples obtained by the soundcard.

The energy of the reconstructed input signal \tilde{x}_k is

$$\begin{aligned}
\|\tilde{x}_k\|_2 &= \int_{-\infty}^{\infty} \left| \sum_{\ell=1}^L x_{k,\ell} \operatorname{sinc}(F_s t - \ell) \right|^2 dt \\
&= \int_{-\infty}^{\infty} \sum_{\ell=1}^L \sum_{m=1}^L x_{k,\ell} x_{k,m} \operatorname{sinc}(F_s t - \ell) \operatorname{sinc}(F_s t - m) dt \\
&= \sum_{\ell=1}^L \sum_{m=1}^L x_{k,\ell} x_{k,m} \int_{-\infty}^{\infty} \operatorname{sinc}(F_s t - \ell) \operatorname{sinc}(F_s t - m) dt \\
&= \frac{1}{F_s} \sum_{\ell=1}^L x_{k,\ell}^2
\end{aligned}$$

where, on the last line we use the fact that sinc and its time shifts by a nonzero integer $T_m(\operatorname{sinc})$ are **orthogonal** (see Section 5.2). That is,

$$\int_{-\infty}^{\infty} \operatorname{sinc}(t) \operatorname{sinc}(t - m) dt = \begin{cases} 1 & m = 0 \\ 0 & m \neq 0. \end{cases} \quad (3.10)$$

Similarly, the energy of the reconstructed output signal \tilde{y}_k is

$$\|\tilde{y}_k\|_2 = \frac{1}{F_s} \sum_{\ell=1}^L y_{k,\ell}^2.$$

So, to compute the energy of the reconstructed signals it suffices to sum the squares of the samples and divide by the sample rate F_s . In view of (3.9), we expect the approximate relationship

$$\frac{\|\tilde{y}_k\|_2}{\|\tilde{x}_k\|_2} \approx |\Lambda(H, f_k)|^2 = \frac{1}{1 + 4\pi^2 R^2 C^2 f_k^2}. \quad (3.11)$$

Each signal x_k is played for a period of approximately 1 second and approximately $L \approx F_s = 44100$ samples are obtained. On the soundcard hardware used for this test samples near the beginning and end of playback are distorted. This appears to be an unavoidable feature of the soundcard. To alleviate this we discard the first $A - 1 = 9999$ samples and use only the $B = 8820$ samples that follow (corresponding to 200ms of signal). In view of (3.11), we expect the relationship

$$\sqrt{\frac{\sum_{\ell=A}^{A+B} y_{k,\ell}^2}{\sum_{\ell=A}^{A+B} x_{k,\ell}^2}} \approx |\Lambda(H, f)| = \sqrt{\frac{1}{1 + 4\pi^2 R^2 C^2 f_k^2}}.$$

Figure 31 displays a plot of the hypothesised spectrum $|\Lambda(H, f)|$ (solid line) and also the spectrum measured using the left hand side of the approximate equation

above (dots). The measurements are close to the hypothesised spectrum, but are consistently a small amount larger. The amplifier appears to produce a slightly larger output voltage than expected. This could be due to inaccuracies in the components used, and also due to our assumption of an ideal operational amplifier.

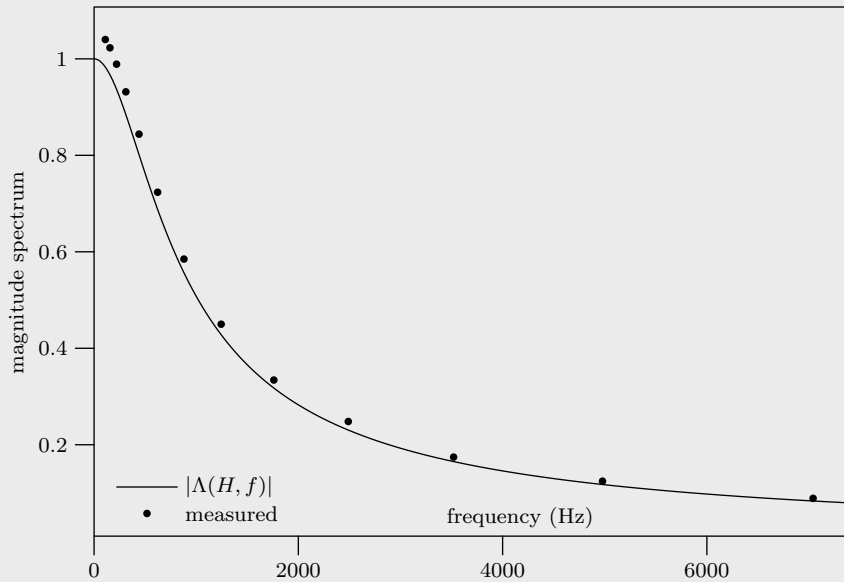

Figure 31: Plot of the hypothesised magnitude spectrum $|\Lambda(H, f)|$ (solid line) and the measured magnitude spectrum (dots).

3.6 Exercises

- 3.1. Show that convolution distributes with addition and commutes with scalar multiplication, that is, show that $a(x*w)+b(y*w) = (ax+by)*w$. **Solution:**

$$\begin{aligned}
 a(x * w) + b(y * w) &= a \int_{-\infty}^{\infty} x(\tau)w(t - \tau)d\tau + b \int_{-\infty}^{\infty} y(\tau)w(t - \tau)d\tau \\
 &= \int_{-\infty}^{\infty} (ax(\tau) + by(\tau))w(t - \tau)d\tau \\
 &= (ax + by) * w.
 \end{aligned}$$

- 3.2. Show that convolution is associative. That is, if x, y, z are signals then

$x * (y * z) = (x * y) * z$. **Solution:**

$$\begin{aligned}
 (x * y) * z &= \int_{-\infty}^{\infty} (x * y)(\tau)z(t - \tau)d\tau \\
 &= \int_{-\infty}^{\infty} \int_{-\infty}^{\infty} x(\kappa)y(\tau - \kappa)z(t - \tau)d\kappa d\tau \\
 &= \int_{-\infty}^{\infty} x(\kappa) \int_{-\infty}^{\infty} y(\tau - \kappa)z(t - \tau)d\tau d\kappa && \text{(swap order of integration)} \\
 &= \int_{-\infty}^{\infty} x(\kappa) \int_{-\infty}^{\infty} y(\nu)z(t - \kappa - \nu)d\nu d\kappa && \text{(change variable } \nu = \tau - \kappa) \\
 &= \int_{-\infty}^{\infty} x(\kappa)(y * z)(t - \kappa)d\kappa \\
 &= x * (y * z).
 \end{aligned}$$

The exchange of integration order can be justified using Fubini's theorem whenever the all of the convolutions involved in $x * (y * z) = (x * y) * z$ exist.

3.3. Show that a regular system is stable if and only if its impulse response is absolutely integrable. **Solution:** Let H be a regular system and h its impulse response. If h is absolutely integrable then for all signals x such that $|x(t)| < M$ for all t ,

$$\begin{aligned}
 H(x, t) &= h * x \\
 &= \int_{-\infty}^{\infty} h(\tau)x(t - \tau)d\tau \\
 &\leq \int_{-\infty}^{\infty} |h(\tau)x(t - \tau)|d\tau \\
 &\leq \int_{-\infty}^{\infty} M|h(\tau)|d\tau \\
 &= M\|h\|_1
 \end{aligned}$$

for all t , and so $H(x, t)$ is bounded. On the other hand if h is not absolutely integrable then the bounded signal

$$s(t) = \begin{cases} 1 & h(-t) > 0 \\ -1 & h(-t) \leq 0 \end{cases}$$

is such that

$$H(x, 0) = \int_{-\infty}^{\infty} h(\tau)s(-\tau)d\tau = \int_{-\infty}^{\infty} |h(\tau)|d\tau = \infty,$$

and so the signal $H(x)$ is not bounded at $t = 0$.

4 The Laplace transform

Let $x: \mathbb{R} \rightarrow \mathbb{C}$ be a complex valued function of the real line (a signal). The integral

$$\mathcal{L}(x) = \int_{-\infty}^{\infty} x(t)e^{-st} dt, \quad (4.1)$$

when it exists, is called the **Laplace transform** of x . The Laplace transform is a function of the complex parameter s , and if we need to indicate this we write $\mathcal{L}(x)(s)$ or $\mathcal{L}(x, s)$. The Laplace transform does not necessarily exist for all values of $s \in \mathbb{C}$. Let R be the set of real numbers such that $x(t)e^{-\sigma t}$ is absolutely integrable if and only if $\sigma \in R$, that is

$$\int_{-\infty}^{\infty} |x(t)| e^{-\sigma t} dt \quad \text{exists if and only if } \sigma \in R.$$

In this case, the Laplace transform $\mathcal{L}(x, s)$ exists for all s with real part satisfying $\text{Re}(s) \in R$ because

$$|\mathcal{L}(x, s)| = \left| \int_{-\infty}^{\infty} x(t)e^{-st} dt \right| \leq \int_{-\infty}^{\infty} |x(t)| e^{-\text{Re}(s)t} dt < \infty.$$

The subset of the complex plane with real part from R is called the **region of convergence** (ROC) of the signal x .

For example, the Laplace transform of the right sided signal $e^{\alpha t}u(t)$ is

$$\begin{aligned} \mathcal{L}(e^{\alpha t}u(t)) &= \int_{-\infty}^{\infty} e^{\alpha t}e^{-st}u(t)dt \\ &= \int_0^{\infty} e^{(\alpha-s)t} dt \\ &= \lim_{t \rightarrow \infty} \frac{e^{(\alpha-s)t}}{\alpha-s} - \frac{1}{\alpha-s}. \end{aligned}$$

The limit exists for all s with $\text{Re}(\alpha - s) < 0$. Thus, the Laplace transform of $e^{\alpha t}u(t)$ is

$$\mathcal{L}(e^{\alpha t}u(t)) = \frac{1}{s - \alpha} \quad \text{Re}(s) > \text{Re}(\alpha)$$

The region of convergence of $e^{\alpha t}u(t)$ is the subset of the complex plane with real part greater than $\text{Re}(\alpha)$. Figure 32 shows the region of convergence when $\text{Re}(\alpha) = -2$. Now consider the left sided signal $e^{\beta t}u(-t)$ with Laplace transform

$$\mathcal{L}(e^{\beta t}u(-t)) = \lim_{t \rightarrow -\infty} \frac{e^{(\beta-s)t}}{\beta-s} + \frac{1}{\beta-s}.$$

The limit exists only when $\text{Re}(\beta - s) > 0$, and so,

$$\mathcal{L}(e^{\beta t}u(-t)) = \frac{1}{\beta - s} \quad \text{Re}(s) < \text{Re}(\beta).$$

The signal $ae^{\alpha t}u(t) + be^{\beta t}u(-t)$ has Laplace transform

$$\begin{aligned}\mathcal{L}(ae^{\alpha t}u(t) + be^{\beta t}u(-t)) &= \int_{-\infty}^{\infty} (ae^{\alpha t}u(t) + be^{\beta t}u(-t))e^{-st} dt \\ &= a \int_{-\infty}^{\infty} e^{\alpha t}u(t)e^{-st} dt + b \int_{-\infty}^{\infty} e^{\beta t}u(-t)e^{-st} dt \\ &= a\mathcal{L}(e^{\alpha t}u(t)) + b\mathcal{L}(e^{\beta t}u(-t))\end{aligned}$$

that exists only when $\operatorname{Re}(\alpha) < \operatorname{Re}(s) < \operatorname{Re}(\beta)$. The corresponding ROC is shown in Figure 32 when $\operatorname{Re}(\alpha) = -2$ and $\operatorname{Re}(\beta) = 3$. In the previous equation we have discovered that the Laplace transform is **linear**, that is, for signals x and y and constants a and b ,

$$\mathcal{L}(ax + by) = a\mathcal{L}(x) + b\mathcal{L}(y). \quad (4.2)$$

In words: the Laplace transform of a linear combination of signals is the same linear combination of the Laplace transforms of those signals.

In the previous example the Laplace transform does not exist for any s if $\operatorname{Re}(\alpha) \geq \operatorname{Re}(\beta)$, and the region of convergence is correspondingly the empty set. Other signals also have this property. For example, the signal $x(t) = 1$ does not have a Laplace transform because

$$\mathcal{L}(1) = \int_{-\infty}^{\infty} e^{-st} dt = \frac{1}{s} \lim_{t \rightarrow -\infty} e^{-st} - \frac{1}{s} \lim_{t \rightarrow \infty} e^{-st}$$

and the limit as $t \rightarrow -\infty$ exists only when $\operatorname{Re}(s) < 0$ while the limit as $t \rightarrow \infty$ exists only when $\operatorname{Re}(s) > 0$.

As a final example, consider the rectangular pulse

$$\Pi(t) = \begin{cases} 1 & -\frac{1}{2} < t \leq \frac{1}{2} \\ 0 & \text{otherwise.} \end{cases}$$

Its Laplace transform is

$$\mathcal{L}(\Pi) = \int_{-\infty}^{\infty} \Pi(t)e^{-st} dt = \int_{-1/2}^{1/2} e^{-st} dt = \frac{e^{s/2} - e^{-s/2}}{s}, \quad (4.3)$$

and this transform exists for all $s \in \mathbb{C}$. The region of convergence of the rectangular pulse Π is the entire complex plane. The examples just given exhibit all the possible types of regions of convergence. The region of convergence is either the entire complex plane, a left or right half plane, a vertical strip, or the empty set.

Given the Laplace transform $\mathcal{L}(x)$ the signal x can be recovered by the **inverse Laplace transform**

$$x(t) = \mathcal{L}^{-1}(x) = \frac{1}{2\pi j} \lim_{\omega \rightarrow \infty} \int_{\sigma - j\omega}^{\sigma + j\omega} \mathcal{L}(x, s)e^{st} ds,$$

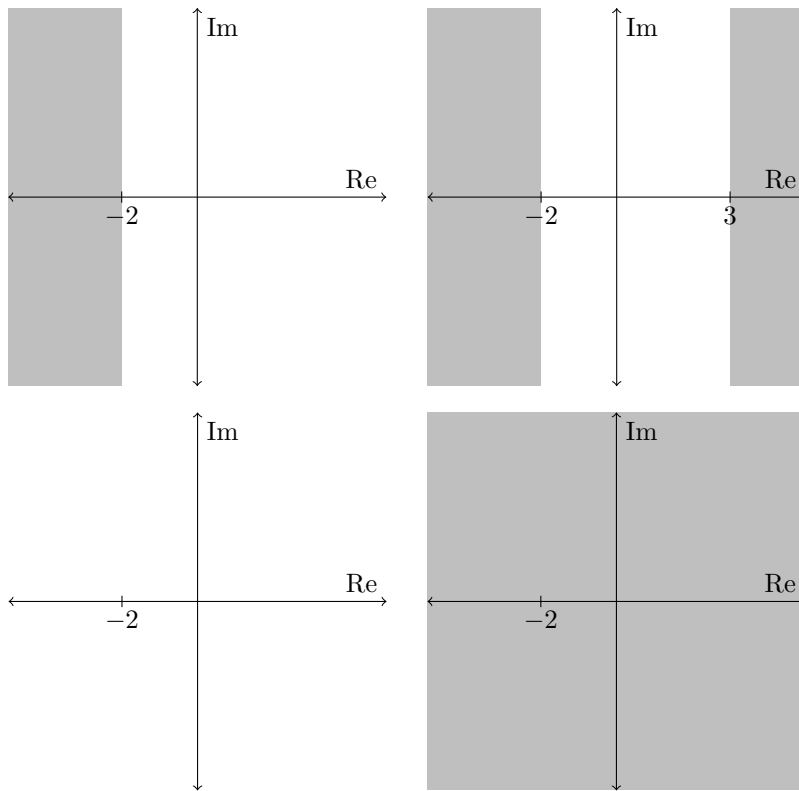

Figure 32: Regions of convergence (unshaded) for the signal $e^{-2t}u(t)$ (top left), the signal $e^{-2t}u(t) + e^{3t}u(-t)$ (top right), the rectangular pulse Π (bottom left), and the constant signal $x(t) = 1$ (bottom right).

where σ is a real number that is inside the region of convergence of x . Solving the integral above typically requires a special type of integration called **contour integration** that we will not consider here [Stewart and Tall, 2004]. For our purposes, and for many engineering purposes, it suffices to remember only the following Laplace transform pair

$$\mathcal{L}(t^n u(t)) = \frac{n!}{s^{n+1}} \quad \text{Re}(s) > 0, \quad (4.4)$$

where $n \geq 0$ is an integer (Exercise 4.2). Let $x(t)$ be a signal with region of convergence R . The Laplace transforms of the signal $x(t)$ and the signal $e^{\alpha t}x(t)$ are related. To see this write

$$\begin{aligned} \mathcal{L}(e^{\alpha t}x(t), s) &= \int_{-\infty}^{\infty} e^{\alpha t}x(t)e^{-st} dt \\ &= \int_{-\infty}^{\infty} x(t)e^{-(s-\alpha)t} dt \\ &= \mathcal{L}(x, s - \alpha) \quad \text{Re}(s - \alpha) \in R. \end{aligned} \quad (4.5)$$

This is called the **frequency shift rule**. Combining the frequency shift rule with (4.4) we obtain the transform pair

$$\mathcal{L}(t^n e^{\alpha t}u(t)) = \mathcal{L}(t^n u(t), s - \alpha) = \frac{n!}{(s - \alpha)^{n+1}} \quad \text{Re}(s) > \text{Re}(\alpha), \quad (4.6)$$

where $n \geq 0$ is an integer. This is the only Laplace transform pair we require here.

4.1 The transfer function and the Laplace transform

Our purpose for introducing the Laplace transform is to study the response of a linear time-invariant system H to exponential signals of the form e^{st} . Recall from Section 3.4 that exponential signals are **eigenfunctions** of linear time-invariant systems. That is, for each $s \in \mathbb{C}$, the response of H to e^{st} is λe^{st} where $\lambda \in \mathbb{C}$ is a constant that does not depend on t , but may depend on s and the system H . To highlight this dependence on H and s we write $\lambda(H, s)$ or $\lambda(H)(s)$. Considered as a function of s , $\lambda(H, s)$ is called the **transfer function** of the system H . For a given system H , we would like to understand how $\lambda(H, s)$ behaves as s changes. In what follows we regularly drop the argument “ (s) ” and simply write $\lambda(H)$ as the transfer function of H .

Assume that H is a regular system with impulse response h . In this case,

$$\begin{aligned} H(e^{st}, t) &= e^{st} \lambda(H, s) = h * e^{st} \\ &= \int_{-\infty}^{\infty} h(\tau) e^{s(t-\tau)} d\tau \\ &= e^{st} \int_{-\infty}^{\infty} h(\tau) e^{-s\tau} d\tau \\ &= e^{st} \mathcal{L}(h, s), \end{aligned}$$

and so, $\lambda(H) = \mathcal{L}(h)$. That is, the transfer function of a regular system is precisely the Laplace transform of its impulse response. The region of convergence of the impulse response describes the set of complex exponential signals e^{st} that can be input to (are in the domain of) the system and we refer to this as the region of convergence of the *system*. In this way, both signals and systems have regions of convergence.

The transfer functions of the time-shifter and differentiator can be obtained by inspection. For the time-shifter

$$T_\tau(e^{st}) = e^{s(t-\tau)} = e^{-s\tau} e^{st} \quad \text{and so} \quad \lambda(T_\tau, s) = e^{-s\tau}. \quad (4.7)$$

The region of convergence is the whole complex plane $s \in \mathbb{C}$. For the special case of the identity system T_0 we obtain $\lambda(T_0, s) = 1$. For the differentiator

$$D(e^{st}) = \frac{d}{dt} e^{st} = s e^{st} \quad \text{and so} \quad \lambda(D, s) = s.$$

The region of convergence is the whole complex plane $s \in \mathbb{C}$. More generally, for the k th differentiator

$$D^k(e^{st}) = \frac{d^k}{dt^k} e^{st} = s^k e^{st} \quad \text{and so} \quad \lambda(D^k, s) = s^k. \quad (4.8)$$

The region of convergence is again the whole complex plane. These results motivate assigning the following Laplace transforms to the delta “function” and its derivatives

$$\mathcal{L}(\delta, s) = 1, \quad \mathcal{L}(\delta^k, s) = s^k.$$

These conventions are common in the literature [Oppenheim et al., 1996].

4.1.1 The transfer function of a linear combination of systems

Let $H = aH_1 + bH_2$ be a linear combination of systems H_1 and H_2 . Let $R_1 \subseteq \mathbb{C}$ and $R_2 \subseteq \mathbb{C}$ be the regions of convergence of H_1 and H_2 . We have,

$$\begin{aligned} H(e^{st}) &= aH_1(e^{st}) + bH_2(e^{st}) \\ &= a\lambda(H_1)e^{st} + b\lambda(H_2)e^{st} && s \in R_1 \cap R_2, \\ &= (a\lambda(H_1) + b\lambda(H_2))e^{st} && s \in R_1 \cap R_2, \\ &= \lambda(H)e^{st} && s \in R_1 \cap R_2, \end{aligned}$$

and so,

$$\lambda(H) = a\lambda(H_1) + b\lambda(H_2) \quad s \in R_1 \cap R_2.$$

That is, the transfer function of a linear combination of systems is the same linear combination of the transfer functions. The region of convergence of the linear combination is the intersection of the regions of convergence of the systems being combined.

4.1.2 The transfer function of a composition of systems

Let H be the system constructed by composing two systems H_1 and H_2 with regions of convergence R_1 and R_2 , that is, $H(x) = H_1(H_2(x))$. The response of H to the signal e^{st} is

$$\begin{aligned} H(e^{st}) &= H_1(H_2(e^{st})) \\ &= H_1(\lambda(H_2)e^{st}) && s \in R_2 \\ &= \lambda(H_2)H_1(e^{st}) && s \in R_2 \\ &= \lambda(H_2)\lambda(H_1)e^{st} && s \in R_1 \cap R_2 \\ &= \lambda(H)e^{st} && s \in R_1 \cap R_2, \end{aligned}$$

and so,

$$\lambda(H) = \lambda(H_1)\lambda(H_2) \quad s \in R_1 \cap R_2. \quad (4.9)$$

That is, the transfer function of a composition of linear time invariant systems is the multiplication of the transfer functions of those systems. The region of convergence of the composition is the intersection of the regions of convergence of the systems being composed.

4.1.3 The convolution theorem

We showed in Section 3.3 that if H_1 and H_2 are regular systems with impulse responses h_1 and h_2 , then the impulse of the system $H(x) = H_1(H_2(x))$ is given by the convolution $h = h_1 * h_2$. Because,

$$\lambda(H) = \mathcal{L}(h) \quad \lambda(H_1) = \mathcal{L}(h_1) \quad \lambda(H_2) = \mathcal{L}(h_2),$$

and using (4.9), we obtain,

$$\mathcal{L}(h_1 * h_2) = \mathcal{L}(h) = \lambda(H) = \lambda(H_1)\lambda(H_2) = \mathcal{L}(h_1)\mathcal{L}(h_2), \quad s \in R_1 \cap R_2.$$

Putting $x = h_1$, $y = h_2$, $R_x = R_1$, and $R_y = R_2$ we obtain the **convolution theorem**,

$$\mathcal{L}(x * y) = \mathcal{L}(x)\mathcal{L}(y), \quad s \in R_x \cap R_y. \quad (4.10)$$

In words: the Laplace transform of a convolution of signals is the multiplication of their Laplace transforms.

4.1.4 The Laplace transform of an output signal

Let H be a regular system with impulse response h and let $y = H(x) = h * x$ be the response of H to input signal x . Using the convolution theorem, the Laplace transform of the output signal y is

$$\mathcal{L}(y) = \mathcal{L}(h)\mathcal{L}(x) = \lambda(H)\mathcal{L}(x), \quad s \in R \cap R_x, \quad (4.11)$$

where R is the region of convergence of the system H and R_x is the region of convergence of the input signal x . Thus, the Laplace transform of the output signal $y = H(x)$ is the transfer function of the system H multiplied by the Laplace transform of the input signal x . This result also holds when H is a time-shifter or a differentiator (Exercise 4.11).

4.2 Solving differential equations

Assume we have a system modelled by a differential equation of the form

$$\sum_{\ell=0}^m a_{\ell} D^{\ell}(x) = \sum_{\ell=0}^k b_{\ell} D^{\ell}(y), \quad (4.12)$$

where x and y are signals. Taking Laplace transforms of both sides of this equation,

$$\begin{aligned} \mathcal{L}\left(\sum_{\ell=0}^m a_{\ell} D^{\ell}(x)\right) &= \mathcal{L}\left(\sum_{\ell=0}^k b_{\ell} D^{\ell}(y)\right) \\ \sum_{\ell=0}^m a_{\ell} \mathcal{L}(D^{\ell}(x)) &= \sum_{\ell=0}^k b_{\ell} \mathcal{L}(D^{\ell}(y)) && \text{(linearity (4.2))} \\ \sum_{\ell=0}^m a_{\ell} \lambda(D^{\ell}) \mathcal{L}(x) &= \sum_{\ell=0}^k b_{\ell} \lambda(D^{\ell}) \mathcal{L}(y) && \text{(using (4.11))} \\ \sum_{\ell=0}^m a_{\ell} s^{\ell} \mathcal{L}(x) &= \sum_{\ell=0}^k b_{\ell} s^{\ell} \mathcal{L}(y). && \text{(since } \lambda(D^{\ell}) = s^{\ell} \text{ by (4.8))} \end{aligned}$$

We have obtained an equation relating the Laplace transforms of x and y ,

$$\mathcal{L}(x)(a_0 + a_1 s + \dots a_m s^m) = \mathcal{L}(y)(b_0 + b_1 s + \dots b_k s^k).$$

Rearranging this equation we obtain

$$\mathcal{L}(y) = \frac{a_0 + a_1 s + \dots a_m s^m}{b_0 + b_1 s + \dots b_k s^k} \mathcal{L}(x).$$

Let H be a system such that $y = H(x)$ whenever x and y satisfy the differential equation (4.12). According to (4.11) the transfer function of H is

$$\lambda(H) = \frac{\mathcal{L}(y)}{\mathcal{L}(x)} = \frac{a_0 + a_1 s + \dots a_m s^m}{b_0 + b_1 s + \dots b_k s^k}.$$

Properties of H can be obtained by inspecting this transfer function. For example, the impulse response of H (if it exists) can be obtained by applying the inverse Laplace transform.

We now apply these results to the differential equations that model the RC electrical circuit from Figure 10 and the mass spring damper from Figure 11. The RC circuit is an example of what is called a **first order system** and the mass, spring, damper is an example of what is called a **second order system**.

4.3 First order systems

Recall the passive electrical RC circuit from Figure 10. The differential equation modelling this circuit is (2.1),

$$x = y + RCD(y),$$

where x is the input voltage signal, y is the voltage over the capacitor, and R and C are the resistance and capacitance. The RC circuit is an example of a **first order system**. Let H be a system mapping the input voltage signal x to the output voltage signal y . We will discover the impulse response of H . Taking the Laplace transform on both sides of the differential equation gives

$$\mathcal{L}(x) = (1 + RCs)\mathcal{L}(y),$$

and it follows that the transfer function of H is

$$\lambda(H) = \frac{\mathcal{L}(y)}{\mathcal{L}(x)} = \frac{1}{1 + RCs} = \frac{r}{r + s},$$

where $r = \frac{1}{RC}$. The value $\frac{1}{r} = RC$ is called the **time constant**. The impulse response of H is given by the inverse of this Laplace transform. There are two signals with Laplace transform $\frac{r}{r+s}$: the right sided signal $re^{-rt}u(t)$ with region of convergence $\text{Re}(s) > -r$, and the left sided signal $-re^{-rt}u(-t)$ with region of convergence $\text{Re}(s) < -r$. The RC circuit (and in fact all physically realisable systems) are expected to be causal. For this reason, the left sided signal $-re^{-rt}u(-t)$ cannot be the impulse response of H . The impulse response is the right sided signal

$$h(t) = re^{-rt}u(t).$$

Given an input voltage signal x we can now find the corresponding output signal $y = H(x)$ by convolving x with the impulse response h . That is,

$$y = H(x) = h * x = \int_{-\infty}^{\infty} re^{-r\tau}u(\tau)x(t - \tau)d\tau = r \int_0^{\infty} e^{-r\tau}x(t - \tau)d\tau.$$

If $r \geq 0$ the impulse response is absolutely integrable, that is,

$$\begin{aligned} \|h\|_1 &= \int_{-\infty}^{\infty} |re^{-rt}u(t)| dt \\ &= r \int_0^{\infty} e^{-rt} dt \\ &= 1 - \lim_{t \rightarrow \infty} e^{-rt} = 1, \end{aligned}$$

and the system is stable (Exercise 3.3). However, if $r < 0$ the impulse response is not absolutely integrable, and the system is not stable. Figure 34 shows the impulse response when $r = -\frac{1}{5}, -\frac{1}{3}, -\frac{1}{2}, -\frac{1}{2}, 1, 2$. In a passive electrical RC circuit the resistance R and capacitance C are always positive and $r = \frac{1}{RC}$ is positive. For this reason, passive electrical RC circuits are always stable.

From (3.4), the step response $H(u)$ is given by applying the integrator I_{∞} to the impulse response, that is,

$$H(u) = I_{\infty}(h) = \int_{-\infty}^t \tau e^{-r\tau}u(\tau)d\tau = \begin{cases} \tau \int_0^t e^{-r\tau}d\tau & t > 0 \\ 0 & \text{otherwise} \end{cases}$$

or more simply

$$H(u) = (1 - e^{-rt})u(t). \quad (4.13)$$

This step response is plotted in Figure 34.

Test 5 (The active RC circuit again) In this test we repeat the experiment with the active RC circuit from Test 3 with resistors $R = R_1 = R_2 = 27\text{k}\Omega$ and capacitors $C = C_2 = 10\text{nF}$. In Test 3 we applied the differential equation (2.8) to the reconstructed output signal \tilde{y} and asserted that the resulting signal was close to the reconstructed input signal \tilde{x} . In this test we instead convolve the input signal \tilde{x} with the impulse response

$$h = -\frac{1}{RC}e^{-t/RC} = -re^{-rt}, \quad r = \frac{1}{RC} = \frac{100000}{27},$$

and assert that the resulting signal is close to the output signal \tilde{y} . That is, we test the expected relationship

$$\tilde{y} \approx h * \tilde{x} = -\int_{-\infty}^{\infty} re^{-r\tau}u(\tau)\tilde{x}(t-\tau)d\tau = -r\int_0^{\infty} e^{-r\tau}\tilde{x}(t-\tau)d\tau.$$

From (1.8),

$$\begin{aligned} \tilde{y}(t) &\approx -r\int_0^{\infty} e^{-r\tau}\sum_{\ell=1}^L x_{\ell}\text{sinc}(F_s t - F_s \tau - \ell)d\tau \\ &= -r\sum_{\ell=1}^L x_{\ell}\int_0^{\infty} e^{-r\tau}\text{sinc}(F_s t - F_s \tau - \ell)d\tau \\ &= -r\sum_{\ell=1}^L x_{\ell}f(F_s t - \ell), \end{aligned}$$

where the function

$$f(t) = \int_0^{\infty} e^{-r\tau}\text{sinc}(t - F_s \tau)d\tau.$$

An approximation of $f(t)$ is made using the trapezoidal sum

$$f(t) \approx \frac{K}{2N} \left(g(0) + g(K) + 2 \sum_{n=1}^{N-1} g(\Delta n) \right),$$

where $g(\tau) = e^{-r\tau}\text{sinc}(t - F_s \tau)$, and

$$K = -RC \log(10^{-3}), \quad N = \lceil 10F_s K \rceil, \quad \Delta = K/N.$$

Figure 33 plots the input signal \tilde{x} , output signal \tilde{y} , and hypothesised output signal $h * \tilde{x}$ over a 4ms window.

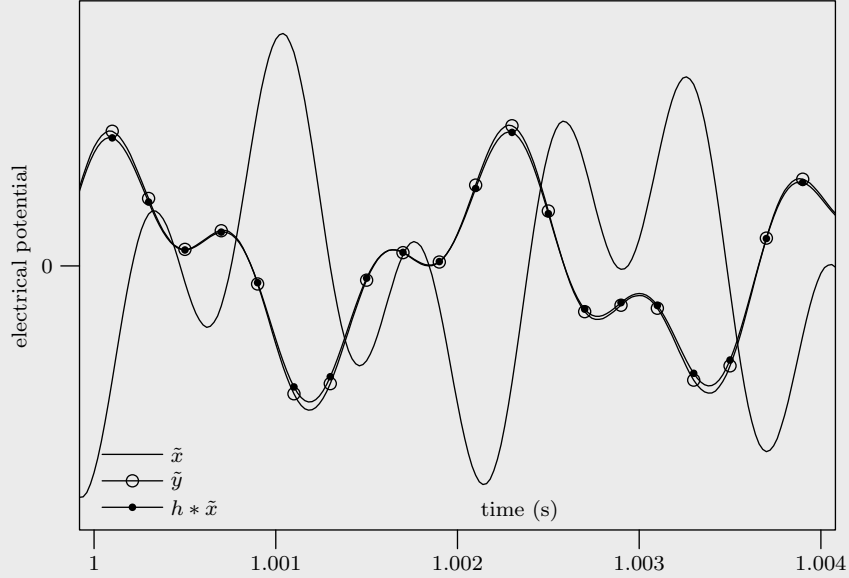

Figure 33: Plot of reconstructed input signal \tilde{x} (solid line), output signal \tilde{y} (solid line with circle), and hypothesised output signal $h * \tilde{x}$ (solid line with dot).

4.4 Second order systems

Consider the mass, spring, damper system from Figure 11 that is described by the equation

$$f = Kp + BD(p) + MD^2(p), \quad (4.14)$$

where f is the force applied to the mass M and p is the position of the mass and K and B are the spring and damping coefficients. The mass spring damper is an example of a **second order system**. Another example of a second order system is the Sallen-Key active electrical circuit depicted in Figure 20. In Section 2 we were able to find the force f corresponding with a given position signal p . Let H be a system mapping f to p , that is, such that $p = H(f)$. We will find the impulse response of H . Taking Laplace transforms on both sides of the differential equation gives

$$\mathcal{L}(f) = (K + Bs + Ms^2)\mathcal{L}(p).$$

Rearranging gives the transfer function of H ,

$$\lambda(H) = \frac{\mathcal{L}(p)}{\mathcal{L}(f)} = \frac{1}{K + Bs + Ms^2}.$$

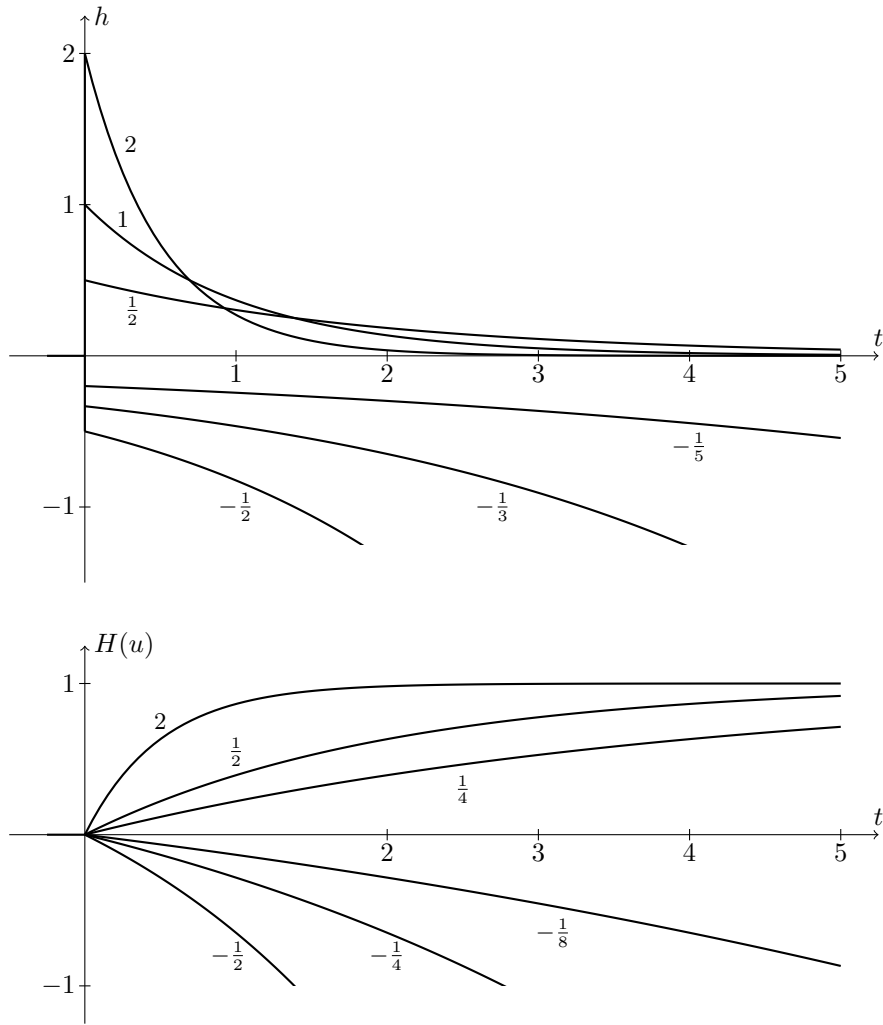

Figure 34: Top: impulse response of a first order system with $r = -\frac{1}{2}, -\frac{1}{3}, -\frac{1}{5}, \frac{1}{2}, 1, 2$. Bottom: step response of a first order system with $r = -\frac{1}{2}, -\frac{1}{4}, -\frac{1}{8}, \frac{1}{4}, \frac{1}{2}, 2$.

We can invert this Laplace transform to obtain the impulse response. There are three cases to consider, depending on whether the quadratic $K + Bs + Ms^2$ has two distinct real roots, is irreducible (does not have real roots), or has two identical real roots.

Case 1: (Distinct real roots) In this case, the roots are

$$\beta - \alpha, \quad -\beta - \alpha,$$

where

$$\alpha = \frac{B}{2M}, \quad \beta = \frac{\sqrt{B^2 - 4KM}}{2M}$$

and $B^2 - 4KM > 0$. By a partial fraction expansion (Exercise 4.7),

$$\begin{aligned} \lambda(H) &= \frac{1}{M(s - \beta + \alpha)(s + \beta + \alpha)} \\ &= \frac{1}{2\beta M} \left(\frac{1}{s - \beta + \alpha} - \frac{1}{s + \beta + \alpha} \right). \end{aligned}$$

From (4.6), we obtain the transform pairs

$$\mathcal{L}(e^{(\beta-\alpha)t}u(t)) = \frac{1}{s - \beta + \alpha}, \quad \mathcal{L}(e^{-(\beta+\alpha)t}u(t)) = \frac{1}{s + \beta + \alpha}.$$

As in Section 4.3, other signals with these Laplace transforms are discarded because they do not lead to an impulse response that is zero for $t < 0$. That is, they do not lead to a causal system H . The impulse response of H is thus

$$h(t) = \frac{1}{2\beta M} u(t) e^{-\alpha t} (e^{\beta t} - e^{-\beta t}).$$

This is a sum of the impulse response of two first order systems.

Case 2: (Distinct imaginary roots) The solution is as in the previous case, but now $4KM - B^2 > 0$ and β is imaginary. Put $\theta = \beta/j$ so that

$$e^{\beta t} - e^{-\beta t} = e^{j\theta t} - e^{-j\theta t} = 2j \sin(\theta t).$$

The impulse response of H is

$$h(t) = \frac{1}{\theta M} u(t) e^{-\alpha t} \sin(\theta t).$$

Case 3: (Identical roots) In this case, the two roots are equal to $-\alpha$ and

$$\lambda(H) = \frac{1}{M(s + \alpha)^2}.$$

From (4.6) we obtain the transform pair

$$\mathcal{L}(te^{-\alpha t}u(t)) = \frac{1}{(s + \alpha)^2},$$

and this is the only signal with this Laplace transform that leads to a causal impulse response. The impulse response of H is thus

$$h(t) = \frac{1}{M}te^{-\alpha t}u(t).$$

A second order system is called **overdamped** when there are two distinct real roots, **underdamped** when there are two distinct imaginary roots, and **critically damped** when the roots are identical. The different types of impulse responses for are plotted in Figure 35.

With no damping (i.e. damping coefficient $B = 0$) the roots are of the form $\pm j\beta$ and have no real part. In this case, the impulse response is

$$h(t) = \frac{1}{\theta M}u(t)\sin(\theta t),$$

where $\theta = \beta/j = \sqrt{KM}$ is called the **natural frequency** of the second order system. This impulse response oscillates for all $t > 0$ without decay or explosion. Two identical roots occur when the damping coefficient $B = \sqrt{4KM}$, and this is sometimes called the **critical damping coefficient**.

The impulse response of a second order system is absolutely integrable when $\alpha = \frac{B}{2M} > 0$, but not when $\alpha \leq 0$. Thus, the system is stable when $\alpha > 0$ and not stable when $\alpha \leq 0$. For the mass spring damper both the mass M and damping coefficient B are positive, and so, mass spring dampers are always stable.

From (3.4) the step response $H(u)$ is given by applying the integrator I_∞ to the impulse response. There are three cases to consider depending on whether the system is overdamped, underdamped, or critically damped. When the system is overdamped the step response is

$$\begin{aligned} H(u) = I_\infty(h) &= \frac{1}{2\beta M} \int_{-\infty}^t e^{-\alpha\tau} (e^{\beta\tau} - e^{-\beta\tau}) u(\tau) d\tau \\ &= \frac{1}{2\beta M} \int_0^t e^{-\alpha\tau} (e^{\beta\tau} - e^{-\beta\tau}) d\tau \\ &= \frac{1}{2\beta M} u(t) \left(\frac{e^{(\beta-\alpha)t} - 1}{\beta - \alpha} + \frac{e^{-(\beta+\alpha)t} - 1}{\beta + \alpha} \right). \end{aligned}$$

When the system is underdamped the step response is

$$\begin{aligned} H(u) = I_\infty(h) &= \frac{1}{\theta M} \int_0^t e^{-\alpha\tau} \sin(\theta\tau) d\tau \\ &= u(t) \left(\frac{\theta - e^{-t\alpha} (\theta \cos(t\theta) + \alpha \sin(t\theta))}{M\theta(\alpha^2 + \theta^2)} \right). \end{aligned}$$

When the system is critically damped the step response is

$$\begin{aligned} H(u) = I_\infty(h) &= \frac{1}{\theta M} \int_0^t \frac{1}{M} t e^{-\alpha t} dt \\ &= \frac{1}{M\alpha^2} u(t) (1 - e^{-t\alpha} (1 + t\alpha)). \end{aligned}$$

These step responses are plotted in Figure 36.

4.5 Poles, zeros, and stability

As discussed in Section 4.2 the transfer function of a system described by a linear differential equation with constant coefficients is of the form

$$\lambda(H) = \frac{\mathcal{L}(y)}{\mathcal{L}(x)} = \frac{a_0 + a_1 s + \dots + a_m s^m}{b_0 + b_1 s + \dots + b_k s^k}.$$

Factorising the polynomials on the numerator and denominator we obtain

$$\lambda(H) = C \frac{(s - \alpha_0)(s - \alpha_1) \cdots (s - \alpha_m)}{(s - \beta_0)(s - \beta_1) \cdots (s - \beta_k)},$$

where $\alpha_0, \dots, \alpha_m$ are the roots of the numerator polynomial $a_0 + a_1 s + \dots + a_m s^m$, and β_0, \dots, β_k are the roots of the denominator polynomial $b_0 + b_1 s + \dots + b_k s^k$, and $C = \frac{a_m}{b_m}$. That such a factorisation is always possible is called the **fundamental theorem of algebra** [Fine and Rosenberger, 1997]. If the numerator and denominator polynomials share one or more roots, then these roots cancel leaving the simpler expression

$$\lambda(H) = C \frac{(s - \alpha_d)(s - \alpha_1) \cdots (s - \alpha_m)}{(s - \beta_d)(s - \beta_1) \cdots (s - \beta_k)}, \quad (4.15)$$

where d is the number of shared roots, these shared roots being

$$\alpha_0 = \beta_0, \quad \alpha_1 = \beta_1, \quad \dots, \quad \alpha_{d-1} = \beta_{d-1}.$$

The roots from the numerator $\alpha_d, \dots, \alpha_m$ are called the **zeros** and the roots from the denominator β_d, \dots, β_m are called the **poles**. A **pole-zero plot** is constructed by marking the complex plane with a cross at the location of each pole and a circle at the location of each zero. Pole-zero plots for the first order system from Section 4.3, the second order system from Section 4.4, and the system describing the PID controller (2.11) are shown in Figure 37.

It is always possible to apply partial fractions and write (4.15) in the form

$$\lambda(H) = p(s) + \sum_{\ell \in K} \frac{A_\ell}{(s - \beta_\ell)^{r_\ell}},$$

where r_ℓ are positive integers, A_ℓ are constants, K is a subset of the indices from $\{d, d+1, \dots, k\}$, and $p(s)$ is a polynomial of degree $m - k$. If $k > m$ then

Figure 35: Impulse response of the mass spring damper with $M = 1$, $K = \frac{\pi^2}{4}$ and damping constant $B = \frac{\pi}{3}$ (underdamped), $B = \sqrt{4KM} = \pi$ (critically damped), and $B = 2\pi$ (overdamped).

Figure 36: Step response of the mass spring damper with $M = 1$, $K = \frac{\pi^2}{4}$ and damping constant $B = \frac{\pi}{3}$ (underdamped), $B = \sqrt{4KM} = \pi$ (critically damped), and $B = 2\pi$ (overdamped).

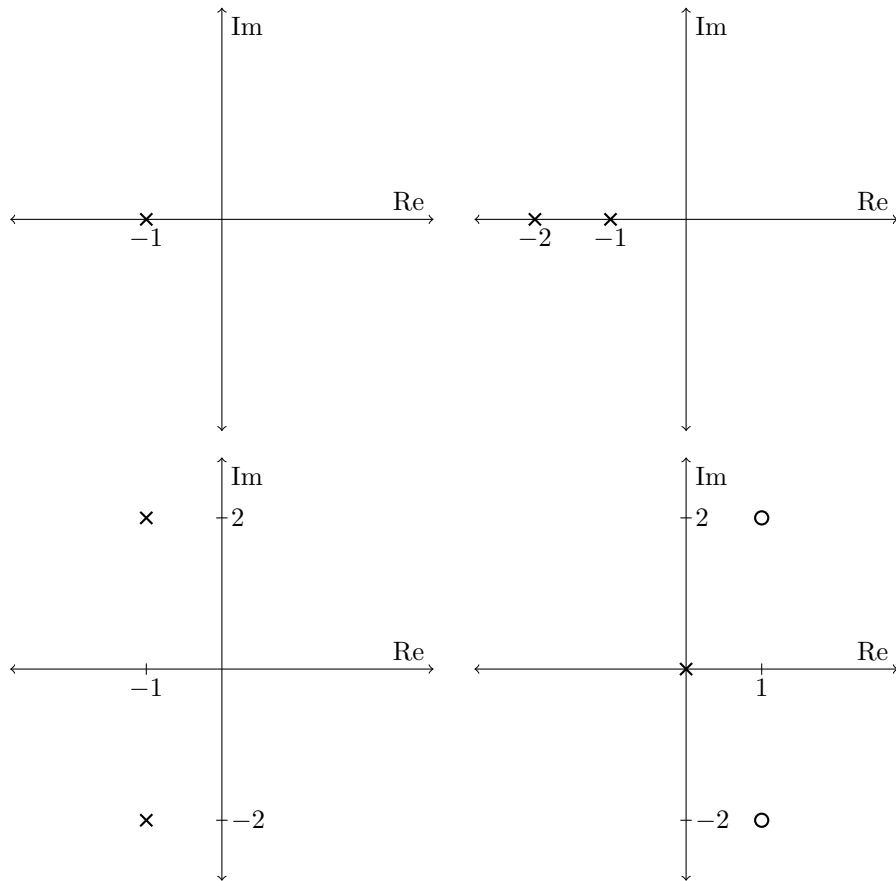

Figure 37: Top left: pole zero plot for the first order system $x = y + D(y)$. There is a single pole at -1 . Top right: pole zero plot for the overdamped second order system $x = 2y + 3D(y) + D^2(y)$ that has two real poles at -1 and -2 . Bottom left: pole zero plot for the underdamped second order system $x = 5y + 2D(y) + D^2(y)$ that has two imaginary poles at $-1 + 2j$ and $-1 - 2j$. The poles form a conjugate pair. Bottom right: pole zero plot for the equation $D(y) = 5x - 2D(x) + D^2(x)$ that models a PID controller (2.11). The system has a single pole at the origin and two zeros at $1 + 2j$ and $1 - 2j$.

$p(s) = 0$. The integer r_ℓ is called the **multiplicity** of the pole β_ℓ . We now restrict ourselves to the case when the coefficients of the numerator polynomial a_0, \dots, a_m and the coefficients of the denominator polynomial b_0, \dots, b_k are real. In this case, the coefficients of the polynomial $p(s)$ are real, and the constant A_ℓ is real whenever the corresponding pole β_ℓ is real. If the pole β_ℓ has nonzero imaginary part there always exists another pole β_i such that $\beta_\ell = \beta_i^*$, where β_i^* is the **complex conjugate** of β_i . These poles have the same multiplicity, that is, $r_\ell = r_i$, and also the constants $A_\ell = A_i^*$. Stated another way: the complex poles occur in **conjugate pairs**.

We see that the transfer function contains the summation of two parts: the polynomial $p(s)$, and a sum of terms of the form $\frac{A}{(s-\beta)^r}$. Let $p(s) = \gamma_0 + \gamma_1 s + \dots + \gamma_{k-m} s^{m-k}$. This polynomial is the transfer function of the nonregular system

$$H_1 = \gamma_0 T_0 + \gamma_1 D + \gamma_2 D^2 + \dots + \gamma_{m-k} D^{m-k}.$$

This system is a linear combination of the identity system T_0 and differentiators of order at most $m - k$. From (4.6),

$$\mathcal{L} \left(\frac{A}{r!} t^{r-1} e^{\beta t} u(t) \right) = \frac{A}{(s-\beta)^r} \quad \text{Re}(s) > \text{Re}(\beta),$$

and so, the terms of the form $\frac{A}{(s-\beta)^r}$ correspond with the transfer function of a regular system with impulse response $\frac{A}{r!} t^{r-1} e^{\beta t} u(t)$. Other signals with Laplace transform $\frac{A}{(s-\beta)^r}$ are discarded because they do not correspond with the impulse response of a causal system. Thus, $\sum_{\ell \in K} \frac{A_\ell}{(s-\beta_\ell)^{r_\ell}}$ is the transfer function of the regular system H_2 with impulse response

$$h_2(t) = u(t) \sum_{\ell \in K} \frac{A_\ell}{r_\ell!} t^{r_\ell-1} e^{\beta_\ell t}.$$

Let $K_r = \{\ell \in K ; \text{Im } \beta_\ell = 0\}$ be the indices from K corresponding with the real poles, and let $K_i = \{\ell \in K ; \text{Im } \beta_\ell > 0\}$ be the indices corresponding with those poles with positive imaginary part. Because the imaginary poles occur in conjugate pairs the impulse response h_2 can be written as

$$h_2(t) = u(t) \sum_{\ell \in K_r} \frac{A_\ell}{r_\ell!} t^{r_\ell-1} e^{\beta_\ell t} + u(t) \sum_{\ell \in K_i} \frac{t^{r_\ell-1}}{r_\ell!} (A_\ell e^{\beta_\ell t} + A_\ell^* e^{\beta_\ell^* t}).$$

The terms

$$\begin{aligned} A_\ell e^{\beta_\ell t} + A_\ell^* e^{\beta_\ell^* t} &= |A_\ell| e^{\text{Re } \beta_\ell t} (e^{\text{Im } \beta_\ell t + \angle A_\ell} + e^{-\text{Im } \beta_\ell t - \angle A_\ell}) \\ &= 2 |A_\ell| e^{\text{Re } \beta_\ell t} \cos(\text{Im } \beta_\ell t + \angle A_\ell), \end{aligned}$$

and so, the impulse response is

$$h_2(t) = u(t) \sum_{\ell \in K_r} \frac{A_\ell}{r_\ell!} t^{r_\ell-1} e^{\beta_\ell t} + u(t) \sum_{\ell \in K_i} \frac{2 |A_\ell|}{r_\ell!} t^{r_\ell-1} e^{\text{Re } \beta_\ell t} \cos(\text{Im } \beta_\ell t + \angle A_\ell).$$

This expression can be simplified by putting

$$B_\ell = \begin{cases} \frac{A_\ell}{r_\ell!} & \text{Im } \beta_\ell = 0 \\ 2\frac{A_\ell}{r_\ell!} & \text{Im } \beta_\ell > 0 \end{cases}$$

so that

$$h_2(t) = u(t) \sum_{\ell \in K_r \cup K_i} B_\ell t^{r_\ell - 1} e^{\text{Re } \beta_\ell t} \cos(\text{Im } \beta_\ell t + \angle B_\ell). \quad (4.16)$$

Observe that the impulse response is a real valued signal (as expected).

The system H mapping x to y is the sum of the regular system H_2 and nonregular system H_1 , that is,

$$y = H(x) = H_1(x) + H_2(x).$$

Observe that H is regular only if the system $H_1 = 0$, that is, only if H_1 maps all input signals to the signal $x(t) = 0$ for all $t \in \mathbb{R}$. This occurs only when the polynomial $p(s) = 0$, that is, only when the number of poles exceeds the number of zeros. The system H will be stable if both H_1 and H_2 are stable. Because the differentiator D^ℓ is not stable (Exercise 1.7) the system H_1 is stable if only if the order of the polynomial $p(s)$ is zero, that is, if $p(s) = \gamma_0$ is a constant (potentially $\gamma_0 = 0$). In this case $H_1(x) = \gamma_0 T_0(x)$ is the identity system multiplied by a constant. The polynomial $p(s)$ is a constant only when the order of the denominator polynomial is greater than or equal to the order of the numerator polynomial, that is, when the number of poles is greater than or equal to the number of zeros. The regular system H_2 is stable if and only if its impulse response h_2 is absolutely integrable. This occurs only when the terms $e^{\text{Re } \beta_\ell t}$ inside the sum (4.16) are decreasing as $t \rightarrow \infty$, that is, only if the real part of the poles $\text{Re } \beta_\ell$ are negative. Thus, the system H_2 is stable if and only if the real part of the poles are strictly negative.

The stability of the system H can be immediately determined from its pole-zero plot. The system is stable if and only if:

1. the number of poles is greater than or equal to the number of zeros (there are at least as many crosses on the pole-zero plot as circles),
2. all of the poles (crosses) lie strictly in the left half plane.

The pole-zero plots in Figure 37 all represent stable systems with the exception of the plot on the bottom right (a PID controller). This system has two zeros and only one pole. The single pole is contained on the imaginary axis. It is not strictly in the left half plane.

4.5.1 Two masses, a spring, and a damper

Consider the system involving two masses a spring, and a damper in Figure 21. From (2.16), the equation relating the force applied to the first mass f and the position of the second mass p is

$$f = BD(p) + (M_1 + M_2)D^2(p) - \frac{BM_2}{K}D^3(p) + \frac{M_1M_2}{K}D^4(p),$$

where B is the damping coefficient, K is the spring constant, and M_1 and M_2 are the masses. Taking Laplace transforms

$$\mathcal{L}(f) = s \left(B + (M_1 + M_2)s - \frac{BM_2}{K}s^2 + \frac{M_1M_2}{K}s^3 \right) \mathcal{L}(p),$$

from which, we obtain the transfer function of a system H that maps f to p ,

$$\lambda(H) = \frac{\mathcal{L}(p)}{\mathcal{L}(f)} = \frac{1}{s \left(B + (M_1 + M_2)s - \frac{BM_2}{K}s^2 + \frac{M_1M_2}{K}s^3 \right)}.$$

The system has no zeros and 4 poles. One of these poles always exists at the origin. The system is not stable because this pole is not strictly in the left half of the complex plane.

Consider the specific case when $B = K = M_1 = M_2 = 1$. Factorising the denominator polynomial gives

$$\lambda(H) = \frac{1}{s(s - \beta_1)(s - \beta_2)(s - \beta_2^*)},$$

where

$$\beta_1 = \frac{1}{3} \left(\gamma - \frac{5}{\gamma} - 1 \right) \approx -0.56984,$$

$$\beta_2 = \frac{1}{6} \left(\frac{5(1 + j\sqrt{3})}{\gamma} - (1 - j\sqrt{3})\gamma - \frac{1}{2} \right) \approx -0.21508 + 1.30714j,$$

and $\gamma = \left(\frac{3\sqrt{69}-11}{2} \right)^{1/3}$. Applying partial fractions (Exercise 4.8) gives

$$\lambda(H) = \frac{1}{s(s - \beta_1)(s - \beta_2)(s - \beta_2^*)} = \frac{A_0}{s} + \frac{A_1}{s - \beta_1} + \frac{A_2}{s - \beta_2} + \frac{A_2^*}{s - \beta_2^*},$$

where

$$A_0 = -\frac{1}{\beta_1|\beta_2|^2} = 1, \quad A_1 = \frac{1}{\beta_1|\beta_1 - \beta_2|^2} \approx -0.956611,$$

$$A_2 = \frac{1}{\beta_2(\beta_2 - \beta_1)(\beta_2 - \beta_2^*)} \approx -0.0216944 + 0.212084j.$$

From (4.16), the impulse response of H is

$$h(t) = u(t) \left(A_0 + A_1 e^{\beta_1 t} + 2|A_2| e^{\operatorname{Re} \beta_2 t} \cos(\operatorname{Im} \beta_2 t + \angle A_2) \right).$$

This impulse response is plotted in Figure 38. Observe that h is not absolutely integrable and the system is not stable. The impulse response $h(t)$ does not converge to zero as $t \rightarrow \infty$, and correspondingly, the mass M_2 does not come to rest at position zero in Figure 38. In the figure it is assumed that the spring is at equilibrium when the two masses are $d = 1$ apart. From (2.14), the position of mass M_1 is given by the signal $p_1 = g - d$ where $g = h + M_2 D^2(h)$.

Figure 38: Impulse response of the system with two masses, a spring, and a damper, where $B = K = M_1 = M_2 = 1$.

4.5.2 Direct current motors

Recall the direct current (DC) motor from Figure 23 described by the differential equation from (2.17),

$$v = \left(\frac{RB}{K_\tau} + K_b \right) D(\theta) + \frac{RJ}{K_\tau} D^2(\theta),$$

where v is the input voltage signal and θ is a signal representing the angle of the motor. The constants R, B, K_τ, K_b , and J are related to components of the motor as described in Section 2.4. To simplify the differential equation put $a = \frac{RB}{K_\tau} + K_b$ and $b = \frac{RJ}{K_\tau}$ and the equation becomes

$$v = aD(\theta) + bD^2(\theta).$$

Taking Laplace transforms on both sides of this equation gives the transfer function of a system H that maps input voltage v to motor angle θ ,

$$\lambda(H) = \frac{1}{s(a + bs)}.$$

This system has no zeros and two poles. One pole at $-\frac{a}{b}$ and the other at the origin. The system is not stable because the pole at the origin is not strictly in the left half of the complex plane.

Applying partial fractions we find that

$$\lambda(H) = \frac{1}{as} - \frac{1}{a(s - \beta)}, \quad (4.17)$$

where $\beta = -\frac{a}{b}$. Using (4.6), the impulse response of H is

$$h(t) = \frac{1}{a}u(t)(1 - e^{\beta t}). \quad (4.18)$$

Other signals with Laplace transform (4.17) are discarded because they do not lead to a causal system. The step response $H(u)$ is obtain by applying the integrator system I_∞ to the impulse response, that is

$$H(u) = I_\infty(h) = \frac{1}{a\beta}u(t)(\beta t + e^{\beta t} - 1).$$

The impulse response and step response are plotted in Figure 39 when $K_b = \frac{1}{8}$, $K_\tau = 8$ and $B = R = 1$ and $J = 2$ so that $a = \frac{1}{4}$, $b = \frac{1}{4}$ and $\beta = -1$.

4.6 Exercises

4.1. Sketch the signal

$$x(t) = e^{-2t}u(t) + e^t u(-t)$$

where $u(t)$ is the step function. Find the Laplace transform of $x(t)$ and the corresponding region of convergence (ROC). Sketch the region of convergence on the complex plane. **Solution:**

Figure 39: Impulse response (top) and step response (bottom) of a DC motor with constants $K_b = \frac{1}{4}$, $K_\tau = 8$ and $B = R = J = 1$.

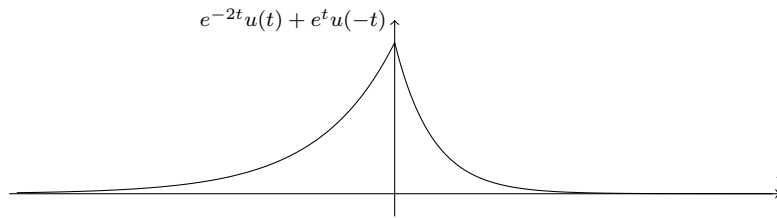

The Laplace transform of $e^{-2t}u(t)$ is

$$\begin{aligned}\mathcal{L}(e^{-2t}u(t), s) &= \int_{-\infty}^{\infty} e^{-2t}u(t)e^{-st} dt \\ &= \int_0^{\infty} e^{-(s+2)t} dt \\ &= -\frac{1}{s+2}, \quad \text{Re}(s) > -2\end{aligned}$$

and the Laplace transform of $e^t u(-t)$ is

$$\begin{aligned}\mathcal{L}(e^t u(-t), s) &= \int_{-\infty}^0 e^{-(s-1)t} dt \\ &= -\frac{1}{s-1}, \quad \text{Re}(s) < 1.\end{aligned}$$

Thus, the Laplace transform of $e^{-2t}u(t) + e^t u(-t)$ is

$$\mathcal{L}(e^{-2t}u(t) + e^t u(-t), s) = -\frac{1}{s+2} - \frac{1}{s-1}, \quad -2 < \text{Re}(s) < 1$$

and the region of convergence (ROC) is the subset of the complex plane satisfying $-2 < \text{Re}(s) < 1$. The unshaded region in the plot below depicts the ROC.

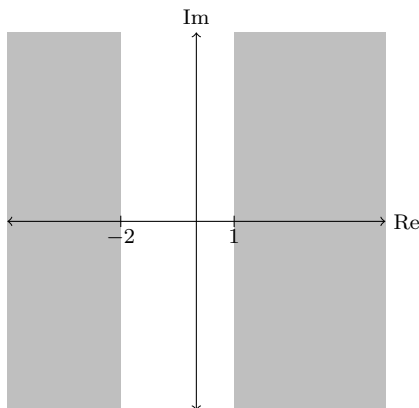

4.2. Find the Laplace transform of the signal $t^n u(t)$ where $n \geq 0$ is an integer.

Solution: We have

$$\mathcal{L}(t^n u(t)) = \int_{-\infty}^{\infty} t^n u(t)e^{-st} dt = \int_0^{\infty} t^n e^{-st} dt.$$

Integration by parts gives the indefinite integral

$$\int t^n e^{-st} dt = \frac{t^n}{s} e^{-st} + \frac{n}{s} \int t^{n-1} e^{-st} dt.$$

So, when $\operatorname{Re}(s) > 0$,

$$\begin{aligned}\mathcal{L}(t^n u(t)) &= \lim_{t \rightarrow 0} \frac{t^n}{s} e^{-st} - \lim_{t \rightarrow \infty} \frac{t^n}{s} e^{-st} + \frac{n}{s} \int_0^\infty t^{n-1} e^{-st} dt \\ &= \frac{n}{s} \mathcal{L}(t^{n-1} u(t)),\end{aligned}$$

since both limits converge to zero. Unravelling the above recursive equation gives

$$\mathcal{L}(t^n u(t)) = \frac{n}{s} \times \frac{n-1}{s} \times \cdots \times \frac{1}{s} \times \mathcal{L}(u(t)) = \frac{n!}{s^{n+1}}, \quad \operatorname{Re}(s) > 0,$$

since $\mathcal{L}(u(t)) = \frac{1}{s}$ when $\operatorname{Re}(s) > 0$.

- 4.3. Show that the Laplace transform of the signal $t^n u(-t)$ where $n \geq 0$ is in integer is the same as the Laplace transform of the signal $t^n u(t)$, but with a different region of convergence. **Solution:** The working is identical to question 4.2, but now the limits converge only when $\operatorname{Re}(s) < 0$, and this is the region of convergence.
- 4.4. Show that equation (4.11) on page 51 holds when the system H is the differentiator D^k or the time shifter T_τ . **Solution:** Put $y = T_\tau(x) = x(t - \tau)$. Taking Laplace transforms

$$\begin{aligned}\mathcal{L}(y) &= \mathcal{L}(T_\tau(x)) \\ &= \int_{-\infty}^\infty T_\tau(x, t) e^{-st} dt \\ &= \int_{-\infty}^\infty x(t - \tau) e^{-st} dt \\ &= \int_{-\infty}^\infty x(\kappa) e^{-s(\kappa + \tau)} d\kappa \quad (\text{ch. vars. } \kappa = t - \tau) \\ &= e^{-s\tau} \int_{-\infty}^\infty x(\kappa) e^{-s\kappa} d\kappa \\ &= e^{-s\tau} \mathcal{L}(x) \\ &= \lambda(T_\tau) \mathcal{L}(x)\end{aligned}$$

as required.

We now show the result for the differentiator D . The argument we use is based on that of Rudin [1986, page 179]. We have just shown that the Laplace transform of the time shifted $T_{-\tau}(x, t) = x(t + \tau)$ is $e^{\tau s} \mathcal{L}(x, s)$. Since the Laplace transform is linear

$$\mathcal{L}\left(\frac{T_{-\tau}(x) - x}{\tau}\right) = \frac{e^{\tau s} - 1}{\tau} \mathcal{L}(x).$$

We now consider what happens to both side of this equation as $\tau \rightarrow 0$. Application of L'Hopitals rule shows that

$$\lim_{\tau \rightarrow 0} \frac{e^{\tau s} - 1}{\tau} = s,$$

and so, the right hand side satisfies

$$\lim_{\tau \rightarrow 0} \frac{e^{\tau s} - 1}{\tau} \mathcal{L}(x) = s \mathcal{L}(x).$$

On the left hand side we have

$$\lim_{\tau \rightarrow 0} \mathcal{L}\left(\frac{T_{-\tau}(x) - x}{\tau}\right) = \lim_{\tau \rightarrow 0} \int_{-\infty}^\infty \frac{x(t + \tau) - x(t)}{\tau} e^{-st} dt.$$

Observe that

$$\lim_{\tau \rightarrow 0} \frac{x(t+\tau) - x(t)}{\tau} = D(x)$$

by definition of the differentiator D . Lebesgue's dominated convergence theorem [Rudin, 1986, page 26] can be used to justify exchanging limits and integration so that

$$\begin{aligned} \lim_{\tau \rightarrow 0} \int_{-\infty}^{\infty} \frac{x(t+\tau) - x(t)}{\tau} e^{-st} dt &= \int_{-\infty}^{\infty} \lim_{\tau \rightarrow 0} \frac{x(t+\tau) - x(t)}{\tau} e^{-st} dt \\ &= \int_{-\infty}^{\infty} D(x, t) e^{-st} dt = \mathcal{L}(D(x)). \end{aligned}$$

We now have $\mathcal{L}(D(x)) = s\mathcal{L}(x) = \lambda(D)\mathcal{L}(x)$ as required.

The result follows for the k th differentiator D^k because

$$\mathcal{L}(D^k(y)) = \mathcal{L}(D(D^{k-1}(y))) = s\mathcal{L}(D^{k-1}(y))$$

and unravelling this recursion gives

$$\mathcal{L}(D^k(y)) = \underbrace{s \times s \times \cdots \times s}_{k-1 \text{ times}} \mathcal{L}(D(y)) = s^k \mathcal{L}(y) = \lambda(D^k)\mathcal{L}(y)$$

as required.

- 4.5. What is the transfer function of the integrator system I_∞ and what is its region of convergence? **Solution:** We have

$$I_\infty(e^{st}, t) = \int_{-\infty}^t e^{s\tau} d\tau = \frac{e^{st}}{s} - \lim_{a \rightarrow -\infty} \frac{e^{sa}}{s}$$

and the limit exists only when $\operatorname{Re} s > 0$ and in this case it is zero. So

$$I_\infty(e^{st}, t) = \frac{1}{s} e^{st} \quad \operatorname{Re} s > 0$$

and $\lambda(I_\infty, s) = \frac{1}{s}$.

- 4.6. By partial fractions, or otherwise, assert that

$$\frac{as}{s+b} = a - \frac{ab}{s+b}$$

Solution: Adding and subtracting ab from the numerator

$$\frac{as + ab - ab}{s+b} = \frac{a(s+b) - ab}{s+b} = \frac{a(s+b)}{s+b} - \frac{ab}{s+b} = a - \frac{ab}{s+b}$$

- 4.7. By partial fractions, or otherwise, assert that

$$\frac{s+c}{(s+a)(s+b)} = \frac{a-c}{(a-b)(s+a)} + \frac{c-b}{(a-b)(s+b)}$$

Solution: Hypothesise the solution

$$\frac{s+c}{(s+a)(s+b)} = \frac{A}{s+a} + \frac{B}{s+b}.$$

Multiplying both sides by $(s+a)(s+b)$,

$$s+c = A(s+b) + B(s+a).$$

Putting $s = -a$ gives $c-a = A(b-a)$, and pitting $s = -b$ gives $c-b = B(a-b)$, and so,

$$\frac{s+c}{(s+a)(s+b)} = \frac{a-c}{(a-b)(s+a)} + \frac{c-b}{(a-b)(s+b)}.$$

4.8. By partial fractions, or otherwise, assert that

$$\frac{1}{s(s-a)(s-b)(s-b^*)} = \frac{A_0}{s} + \frac{A_1}{s-a} + \frac{A_2}{s-b} + \frac{A_2^*}{s-b^*}$$

where $a, b \in \mathbb{C}$ and $\operatorname{Re}(b) \neq 0$, and

$$A_0 = -\frac{1}{a|b|^2}, \quad A_1 = \frac{1}{a|a-b|^2}, \quad A_2 = \frac{1}{b(b-a)(b-b^*)}.$$

You might wish to check your solution using a symbolic programming language (for example Sage, Mathematica, or Maple). **Solution:** The mathematica command

`Apart[1/s/(s - a)/(s - b)/(s - c), s]`

returns the equation

$$\frac{1}{s(s-a)(s-b)(s-c)} = \frac{A_0}{s} + \frac{A_1}{s-a} + \frac{A_2}{s-b} + \frac{A_3}{s-b^*} - \frac{1}{abc} + \frac{1}{a} + \frac{1}{b} + \frac{1}{(s-c)}$$

where

$$A_0 = -\frac{1}{abc}, \quad A_1 = \frac{1}{a(a-b)(a-c)},$$

$$A_2 = \frac{1}{b(b-a)(b-c)}, \quad A_3 = \frac{1}{c(c-a)(c-b)}.$$

Setting $c = b^*$ gives

$$A_0 = -\frac{1}{a|b|^2}, \quad A_1 = \frac{1}{a|a-b|^2},$$

$$A_2 = \frac{1}{b(b-a)(b-b^*)}, \quad A_3 = \frac{1}{b^*(b^*-a)(b^*-b)} = A_2^*$$

as required.

4.9. Let

$$\mathcal{L}(y) = \frac{2s+1}{s^2+s-2}$$

be the Laplace transform of a signal y . By partial fractions, or otherwise, find all possible signals y and their regions of convergence. **Solution:** Factorise the polynomial on the denominator

$$\frac{2s+1}{(s+2)(s-1)}.$$

Adding and subtracting $s-1$ on the numerator

$$\frac{2s+1+(s-1)-(s-1)}{(s+2)(s-1)} = \frac{s-1}{(s-1)(s+2)} + \frac{s+2}{(s-1)(s+2)}$$

$$= \frac{1}{s+2} + \frac{1}{s-1}.$$

There are two time domain signals with Laplace transform $\frac{1}{s+2}$,

$$e^{-2t}u(t), \operatorname{Re}(s) > -2 \quad \text{and} \quad -e^{-2t}u(-t), \operatorname{Re}(s) < -2,$$

and two time domain signals with Laplace transform $-\frac{1}{s-1}$,

$$e^t u(t), \operatorname{Re}(s) > 1 \quad \text{and} \quad -e^t u(-t), \operatorname{Re}(s) < 1.$$

There are three possible signals with nonempty regions of convergence

$$y(t) = e^{-2t}u(t) - e^t u(-t) \quad -2 < \operatorname{Re}(s) < 1,$$

$$y(t) = e^{-2t}u(t) + e^t u(t) \quad 1 < \operatorname{Re}(s),$$

$$y(t) = -e^{-2t}u(-t) - e^t u(-t) \quad \operatorname{Re}(s) < -2.$$

- 4.10. Consider the active electrical circuit from Figure 17 described by the differential equation from (2.7). Derive the transfer function of this system. Find an explicit system H that maps the input voltage x to the output voltage y . State whether this system is stable and/or regular. **Solution:** The differential equation modelling the circuit is

$$-\frac{x}{R_1} - C_1 D(x) = \frac{y}{R_2} + C_2 D(y),$$

and taking Laplace transforms on both sides of this equation

$$\mathcal{L}y = -\frac{\frac{1}{R_1} + C_1 s}{\frac{1}{R_2} + C_2 s} \mathcal{L}(x) = -\frac{\alpha + \gamma s}{\beta + s}$$

where $\alpha = \frac{1}{R_1 C_2}$, $\beta = \frac{1}{R_2 C_2}$, and $\gamma = \frac{C_1}{C_2}$. The transfer function of the system mapping x to y is correspondingly

$$\lambda(H) = -\frac{\alpha + \gamma s}{\beta + s} = -\frac{\alpha}{\beta + s} - \frac{\gamma s}{\beta + s}$$

Applying partial fraction (as in Exercise 4.6) to the second term gives

$$\lambda(H) = -\frac{\alpha + \gamma\beta}{\beta + s} - \gamma$$

The first term $-\frac{\alpha + \gamma\beta}{\beta + s}$ corresponds with a regular system, say H_2 , having impulse response

$$h_2 = -(\alpha + \gamma\beta)u(t)e^{-\beta t}$$

by using the Laplace transform pair from (4.6) with the integer $n = 0$. The term $-\gamma$ correspond with the system $H_1 = \gamma T_0$, i.e, the identity system multiplied by $-\gamma$. The system H that describes the mapping between input voltage x and output voltage y is thus

$$H(x) = H_1(x) + H_2(x) = -\gamma x + h_2 * x.$$

The system is not regular because the H_1 is not regular. The system is stable because H_1 is stable and H_2 is stable because the impulse response h_2 is absolutely integrable since $\beta = \frac{1}{R_2 C_2} > 0$. Equivalently the system is not regular because the transfer function does not have more poles than zero, and the system is stable because the transfer function has at least as many poles as zeros (equal in this case), and because all the poles lie strictly in the left half plane.

- 4.11. Given the mass spring damper system described by (4.14), find the position signal p given that the force signal

$$f(t) = \Pi\left(t - \frac{1}{2}\right) = \begin{cases} 1 & 0 < t \leq 1 \\ 0 & \text{otherwise} \end{cases}$$

is the rectangular function time shifted by $\frac{1}{2}$. Consider three cases:

- (a) $M = 1$, $K = \frac{\pi^2}{4}$ and $B = \frac{\pi}{3}$,
- (b) $M = 1$, $K = \frac{\pi^2}{4}$ and $B = \pi$,
- (c) $M = 1$, $K = \frac{\pi^2}{4}$ and $B = 2\pi$,

Plot the solution in each case, and comment on whether the system is underdamped, overdamped, or critically damped. **Solution:** Observe that the input force signal can be written as the sum of the step function u and its negated time-shift, that is,

$$f(t) = u(t) - u(t - 1) = u(t) - T_1(u, t)$$

and so, the response of the linear, time invariant system H modelling the mass spring damper to input force signal f is

$$H(f) = H(u - T_1(u)) = H(u) - T_1(H(u)),$$

and so, $H(f, t) = H(u, t) - H(u, t - 1)$, where $H(u)$ is the step response of the system. The step responses are described in Section 4.4. As described in Section 4.4, the system is underdamped when $B = \frac{\pi}{3}$, critically damped when $B = \pi$ and overdamped when $B = 2\pi$.

5 The Fourier transform

The **Fourier transform** of an absolutely integrable signal x is defined as

$$\mathcal{F}(x) = \int_{-\infty}^{\infty} x(t)e^{-j2\pi ft} dt. \quad (5.1)$$

The Fourier transform is a function of the real number f , and if we need to indicate this we write $\mathcal{F}(x)(f)$ or $\mathcal{F}(x, f)$. For example, the rectangular pulse $\Pi(t)$ from (1.4) is absolutely integrable and has Fourier transform

$$\begin{aligned} \mathcal{F}(\Pi) &= \int_{-\infty}^{\infty} \Pi(t)e^{-j2\pi ft} dt \\ &= \int_{-1/2}^{1/2} e^{-j2\pi ft} dt \\ &= \frac{e^{j\pi f} - e^{-j\pi f}}{j2\pi f} \\ &= \frac{\sin(\pi f)}{\pi f} = \text{sinc}(f). \end{aligned} \quad (5.2)$$

The sinc function is plotted in Figure 40.

The Fourier transform is closely related to the Laplace transform because

$$\mathcal{F}(x, f) = \mathcal{L}(x, j2\pi f)$$

for those signals x with region of convergence containing the imaginary axis, that is, for absolutely integrable x . The Fourier transform inherits the properties of the Laplace transform that were described in Section 4.1. For example, if H is a regular system with impulse response h that has Fourier transform $\mathcal{F}(h)$, then the spectrum of H satisfies

$$\Lambda(H, f) = \mathcal{L}(h, j2\pi f) = \mathcal{F}(h, f).$$

That is, the spectrum of a regular system (if it exists) is given by the Fourier transform of its impulse response. Like the Laplace transform, the Fourier transform obeys the **convolution theorem** (4.10), that is,

$$\mathcal{F}(x * y) = \mathcal{F}(x)\mathcal{F}(y). \quad (5.3)$$

In words: the Fourier transform of a convolution of signals is given by the multiplication of the Fourier transforms of those signals.

It follows from (4.11) that if H is a regular system with spectrum $\Lambda(H)$ and if x is a signal with Fourier transform $\mathcal{F}(x)$, then the signal $y = H(x)$ has Fourier transform

$$\mathcal{F}(y) = \Lambda(H)\mathcal{F}(x).$$

This property also holds for the differentiator system D and the time shifter system T_τ (Exercise 4.11). From (4.7) and (4.8) the spectrum of T_τ and the k th differentiator D^k satisfy

$$\Lambda(T_\tau, f) = e^{-j2\pi f\tau}, \quad \Lambda(D^k, f) = (j2\pi f)^k$$

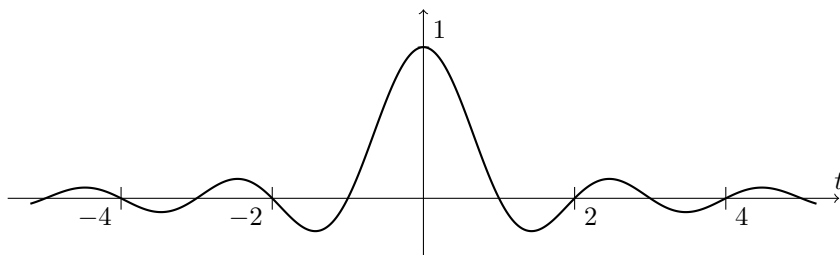

Figure 40: The **sinc function** $\text{sinc}(t) = \frac{\sin(\pi t)}{\pi t}$.

from which we obtain the **time shift property**,

$$\mathcal{F}(T_\tau(x)) = \Lambda(T_\tau)\mathcal{F}(x) = e^{-j2\pi f\tau}\mathcal{F}(x),$$

and the **differentiation property**,

$$\mathcal{F}(D^k(x)) = \Lambda(D^k)\mathcal{F}(x) = (j2\pi f)^k\mathcal{F}(x),$$

of the Fourier transform. These results motivate assigning the following Fourier transforms to the delta “function” and its derivatives

$$\mathcal{F}(\delta, f) = 1, \quad \mathcal{L}(\delta^k, f) = (j2\pi f)^k. \quad (5.4)$$

These conventions are common in the engineering literature [Oppenheim et al., 1996].

Similarly to the Laplace transform (4.5), the Fourier transform obeys a **frequency shift rule** that relates the transform of a signal $x(t)$ to that of the signal $e^{2\pi j\gamma t}x(t)$ where $\gamma \in \mathbb{R}$. From (4.5), the frequency shift rule asserts that

$$\mathcal{F}(e^{2\pi j\gamma t}x(t), f) = \mathcal{F}(x, f - \gamma). \quad (5.5)$$

Since $\cos(2\pi\gamma t) = \frac{1}{2}e^{2\pi j\gamma t} + \frac{1}{2}e^{-2\pi j\gamma t}$ we also have

$$\mathcal{F}(\cos(2\pi\gamma t)x(t), f) = \frac{1}{2}\mathcal{F}(x, f - \gamma) + \frac{1}{2}\mathcal{F}(x, f + \gamma). \quad (5.6)$$

This is sometimes called the **modulation property** of the Fourier transform [Papoulis, 1977, page 61]. This property is of particular importance in communications engineering [Proakis, 2007].

5.1 Duality and the inverse transform

Given a signal x we will often denote its Fourier transform by $\hat{x} = \mathcal{F}(x)$. Observe that \hat{x} , like x , is a function that maps a real number to a complex number. Thus, the Fourier transform \hat{x} is a **signal** with independent variable representing **frequency**. It is usual to call x the **time domain** representation of the signal

and \hat{x} the **frequency domain** representation. If \hat{x} is absolutely integrable, then x can be recovered using the **inverse Fourier transform**

$$x(t) = \mathcal{F}^{-1}(\hat{x}, t) = \int_{-\infty}^{\infty} \hat{x}(f) e^{j2\pi ft} df. \quad (5.7)$$

For example, let $\hat{x} = \mathcal{F}(x) = \Pi$ be the rectangular pulse. By working analogous to that from (5.2),

$$x(t) = \int_{-\infty}^{\infty} \Pi(f) e^{j2\pi ft} df = \text{sinc}(-t) = \text{sinc}(t).$$

We are lead to the conclusion that the Fourier transform of $\text{sinc}(t)$ is the rectangular pulse $\Pi(f)$.

The rectangular pulse Π is finite in time and absolutely integrable. The sinc function is not absolutely integrable (Exercise 5.3). Because of this the integral equation that we have used to define the Fourier transform (5.1) cannot be directly applied to the sinc function. The inverse transform provides a method for assigning Fourier transforms to signals even when the formula (5.1) does not apply. Although sinc is not absolutely integrable, it is square integrable (Exercise 5.3). It can be shown that all square integrable signals have a Fourier transform, and that the Fourier transform is itself square integrable. This is called the **Plancherel theorem** [Rudin, 1986, Th. 9.13]. For our purposes it suffices to remember only that the Fourier transform of the sinc function is the rectangular pulse Π .

Let x be a signal with Fourier transform

$$\hat{x}(f) = \mathcal{F}(x, f) = \int_{-\infty}^{\infty} x(\tau) e^{-j2\pi f\tau} d\tau.$$

Evaluating \hat{x} at $-t$ we find that

$$\hat{x}(-t) = \int_{-\infty}^{\infty} x(\tau) e^{j2\pi t\tau} d\tau = \mathcal{F}^{-1}(x, t).$$

That is, if \hat{x} is the Fourier transform of x , then x is the Fourier transform of \hat{x} reflected in time. Another way to write this is

$$\mathcal{F}(\hat{x}, t) = \mathcal{F}(\mathcal{F}(x), t) = x(-t).$$

Equivalently, if we define

$$R(x, t) = x(-t) \quad (5.8)$$

as the system that reflects its input signal, then

$$\mathcal{F}(\mathcal{F}(x)) = \mathcal{F}^2(x) = R(x),$$

where we use the notation \mathcal{F}^2 to denote application of the Fourier transform twice. This is called the **duality** property of the Fourier transform. Applying the Fourier transform three times to a signal x we obtain

$$\mathcal{F}^3(x) = \mathcal{F}(\mathcal{F}(\mathcal{F}(x))) = R(\mathcal{F}(x)) = \mathcal{F}(R(x)). \quad (5.9)$$

It follows that the Fourier transform commutes with the reflection system R . This is called the **reflection** property of the Fourier transform. Informally stated: a reflection in the time domain causes a corresponding reflection in the frequency domain.

The duality property and (5.4) motivates assigning a Fourier transform the signal 1, that is,

$$\mathcal{F}(1) = R(\delta) = \delta,$$

where we treat the delta function as if it were even, i.e., we assign it the property $\delta(t) = \delta(-t)$ so that $R(\delta) = \delta$. Combining this with the frequency shift rule motivates assigning the following Fourier transform to the complex exponential signal $e^{j2\pi\gamma t}$,

$$\mathcal{F}(e^{j2\pi\gamma t}) = \delta(f - \gamma),$$

and, similarly, motivates assigning the Fourier transforms

$$\mathcal{F}(\cos(2\pi t)) = \mathcal{F}\left(\frac{1}{2}e^{j2\pi\gamma t} + \frac{1}{2}e^{-j2\pi\gamma t}\right) = \frac{1}{2}\delta(f - \gamma) + \frac{1}{2}\delta(f + \gamma)$$

and

$$\mathcal{F}(\sin(2\pi t)) = \mathcal{F}\left(\frac{1}{2j}e^{j2\pi\gamma t} - \frac{1}{2j}e^{-j2\pi\gamma t}\right) = \frac{1}{2j}\delta(f - \gamma) - \frac{1}{2j}\delta(f + \gamma)$$

to the signals $\sin(2\pi t)$ and $\cos(2\pi t)$. These conventions are common in the literature [Oppenheim et al., 1996]. It is important remember that δ is not a signal. It is not a function. The signals 1, $e^{2\pi jt}$, $\cos(2\pi t)$, and $\sin(2\pi t)$ are neither absolutely integrable nor square integrable and do not formally have Fourier transforms. You cannot, for example, apply the integral equation (4.1) to $\cos(2\pi t)$ and expect a meaningful result. Nevertheless, these conventions will often lead to valid results when applied with discretion.

Let $\hat{x} = \mathcal{F}(x)$ and $\hat{y} = \mathcal{F}(y)$ be the Fourier transforms of signals x and y . By duality

$$\mathcal{F}(\hat{x}) = \mathcal{F}^2(x) = R(x), \quad \mathcal{F}(\hat{y}) = \mathcal{F}^2(y) = R(y).$$

Because the product $R(x)R(y) = R(xy)$ we have

$$R(xy) = R(x)R(y) = \mathcal{F}(\hat{x})\mathcal{F}(\hat{y}) = \mathcal{F}(\hat{x} * \hat{y}),$$

where the last inequality follows from the convolution theorem (5.3). Applying the Fourier transform to both sides and using the duality and reflection properties we obtain

$$R(\mathcal{F}(xy)) = R(\hat{x} * \hat{y}).$$

Applying the reflection system R to both sides and using the fact that $R^2 = T_0$ is the identity system we obtain

$$\mathcal{F}(xy) = \hat{x} * \hat{y} = \mathcal{F}(x) * \mathcal{F}(y).$$

Thus, the Fourier transform of a product of signals is the product of the Fourier transforms. This is called the **multiplication theorem**. The multiplication theorem often goes by the phrase: “Multiplication in the time domain is convolution in the frequency domain”.

5.2 Parseval's identity

Let x be a signal with Fourier transform $\hat{x} = \mathcal{F}(x)$. The Fourier transform of x^* , the complex conjugate of x , satisfies

$$\begin{aligned}\mathcal{F}(x^*, f) &= \int_{-\infty}^{\infty} x(t)^* e^{-j2\pi ft} dt \\ &= \int_{-\infty}^{\infty} (x(t)e^{j2\pi ft})^* dt \\ &= \left(\int_{-\infty}^{\infty} x(t)e^{j2\pi ft} dt \right)^* \\ &= \mathcal{F}(x, -f)^* \\ &= \hat{x}(-f)^*.\end{aligned}\tag{5.10}$$

It follows that if x is a real valued signal so that $x = x^*$, then $\hat{x}(f) = \hat{x}(-f)^*$. That is, the Fourier transform of a real valued signal is **conjugate symmetric**.

The convolution theorem (5.3) asserts that $\mathcal{F}(x * y) = \mathcal{F}(x)\mathcal{F}(y) = \hat{x}\hat{y}$. Applying the inverse Fourier transform to both sides of this equation gives²

$$(x * y)(t) = \int_{-\infty}^{\infty} x(\tau)y(t - \tau)d\tau = \int_{-\infty}^{\infty} \hat{x}(f)\hat{y}(f)e^{j2\pi ft} df.$$

Setting $t = 0$ we obtain what is often called **Parseval's identity**

$$\int_{-\infty}^{\infty} x(\tau)y(-\tau)d\tau = \int_{-\infty}^{\infty} \hat{x}(f)\hat{y}(f)df.$$

Putting $y(t) = x(-t)^*$ so that $\hat{y}(f) = \hat{x}(f)^*$ we obtain the special case

$$\int_{-\infty}^{\infty} |x(\tau)|^2 d\tau = \int_{-\infty}^{\infty} |\hat{x}(f)|^2 df,$$

or equivalently $\|x\|_2 = \|\hat{x}\|_2$. In words: the energy of a signal is equal to the energy of its Fourier transform.

In Tests 4 and 6 we made use the fact that sinc and its time shifts by a nonzero integer $T_m(\text{sinc})$ are **orthogonal**. That is,

$$\int_{-\infty}^{\infty} \text{sinc}(t)\text{sinc}(t - m)dt = \begin{cases} 1 & m = 0 \\ 0 & m \neq 0. \end{cases}\tag{5.11}$$

where $m \in \mathbb{Z}$. We now use Parseval's identity to prove this. Applying the frequency shift rule (5.5) to the rectangular pulse Π we have

$$\mathcal{F}(e^{2\pi jmt}\Pi(t), f) = \mathcal{F}(\Pi, f - m) = \text{sinc}(f - m).$$

²The product of two square integrable function is absolutely integrable [Rudin, 1986, Thm 3.8].

Putting $x(t) = e^{2\pi jmt}\Pi(t)$ and $y(t) = \Pi(t)$ in Parseval's identity gives

$$\begin{aligned} \int_{-\infty}^{\infty} \text{sinc}(f - m) \text{sinc}(f) df &= \int_{-\infty}^{\infty} e^{2\pi jm\tau} \Pi(\tau) \Pi(-\tau) d\tau \\ &= \int_{-1/2}^{1/2} e^{2\pi jm\tau} d\tau \\ &= \frac{e^{\pi jm} - e^{-\pi jm}}{2\pi jm} \\ &= \frac{\sin(\pi m)}{\pi m} = \text{sinc}(m). \end{aligned}$$

The result (5.11) follows because $\text{sinc}(m)$ is equal to one when $m = 0$ and equal to zero when m is any other integer (Figure 40).

5.3 Ideal filters

For many engineering purposes it is desirable to construct systems that will pass (have little affect on) a complex exponential signal $e^{j2\pi ft}$ for certain frequencies f , but will reject (significantly attenuate) these signals for other frequencies. Such systems are called **filters**. Those frequencies that the filter intends to pass unaffected are said to be in the **pass band** and those frequencies that the filter intends to reject are said to be in the **stop band**.

For example, an **ideal lowpass filter** with **cutoff frequency** c is the system L_c with spectrum

$$\Lambda(L_c) = \begin{cases} 1 & -c < f \leq c \\ 0 & \text{otherwise} \end{cases} = \Pi\left(\frac{f}{2c}\right).$$

Applying the inverse Fourier transform to $\Pi\left(\frac{f}{2c}\right)$ gives

$$\int_{-\infty}^{\infty} \Pi\left(\frac{f}{2c}\right) e^{j2\pi tf} df = \int_{-c}^c e^{j2\pi tf} df = \frac{\sin(2c\pi t)}{\pi t} = 2c \text{sinc}(2ct).$$

We conclude that the ideal lowpass filter L_c is a regular linear time invariant system with impulse response $2c \text{sinc}(2ct)$.

An **ideal highpass filter** with cutoff frequency c is given by the linear combination $T_0 - L_c$ where T_0 is the identity system. The spectrum is

$$\Lambda(T_0 + L_c) = \Lambda(T_0) + \Lambda(L_c) = 1 - \Pi\left(\frac{f}{2c}\right) = \begin{cases} 0 & -c < f \leq c \\ 1 & \text{otherwise.} \end{cases}$$

This ideal highpass filter is not regular because the system T_0 is not regular. The system does not have a signal representing an impulse response, however, it is common to represent it by $\delta(t) - 2c \text{sinc}(2ct)$ using the delta function as described in Section 3.1.

An **ideal bandpass filter** with upper cutoff frequency u and lower cutoff frequency ℓ is given by the linear combination $L_u - L_\ell$. The spectrum is

$$\Lambda(L_u - L_\ell) = \Pi\left(\frac{f}{2u}\right) - \Pi\left(\frac{f}{2\ell}\right) = \begin{cases} 1 & -u < f \leq -\ell \\ 1 & u < f \leq \ell \\ 0 & \text{otherwise.} \end{cases}$$

It follows that the ideal bandpass filter has impulse response $2u \operatorname{sinc}(2ut) - 2\ell \operatorname{sinc}(2\ell t)$. The spectrum and impulse response of the ideal lowpass, highpass, and bandpass filters are plotted in Figure 41.

5.4 Butterworth filters

The ideal filters described in the previous section are not realisable in practice. One reason for this is that they are not causal because the sinc function is unbounded in time. We now describe a popular practical low-pass filter discovered by Butterworth [1930]. A normalised low pass **Butterworth filter** of order m , denoted by B_m , has transfer function

$$\lambda(B_m) = \frac{1}{\prod_{i=1}^m \left(\frac{s}{2\pi} - \beta_i\right)} = \frac{(2\pi)^m}{\prod_{i=1}^m (s - 2\pi\beta_i)},$$

where β_1, \dots, β_m are the roots of the polynomial $s^{2m} + (-1)^m$ that lie strictly in the left half of the complex plane (have negative real part). It is convenient to precisely define these roots as

$$\beta_k = \begin{cases} \exp\left(j\frac{\pi}{2}\left(1 + \frac{2k-1}{m}\right)\right), & k = 1, \dots, m \\ \exp\left(j\frac{\pi}{2}\left(1 - \frac{2k-1}{m}\right)\right), & k = m+1, \dots, 2m \end{cases}$$

or equivalently

$$\beta_k = \begin{cases} j \cos\left(\frac{\pi(2k-1)}{2m}\right) - \sin\left(\frac{\pi(2k-1)}{2m}\right), & k = 1, \dots, m \\ j \cos\left(\frac{\pi(2k-1)}{2m}\right) + \sin\left(\frac{\pi(2k-1)}{2m}\right), & k = m+1, \dots, 2m. \end{cases}$$

The roots are plotted in Figure 42. Observe that the roots $\beta_{m+1}, \dots, \beta_{2m}$ are given by negating the real parts of β_1, \dots, β_m , that is, $\beta_{m+i} = j(\beta_i/j)^*$.

The spectrum of B_m is

$$\Lambda(B_m) = \frac{1}{\prod_{i=1}^m (jf - \beta_i)}.$$

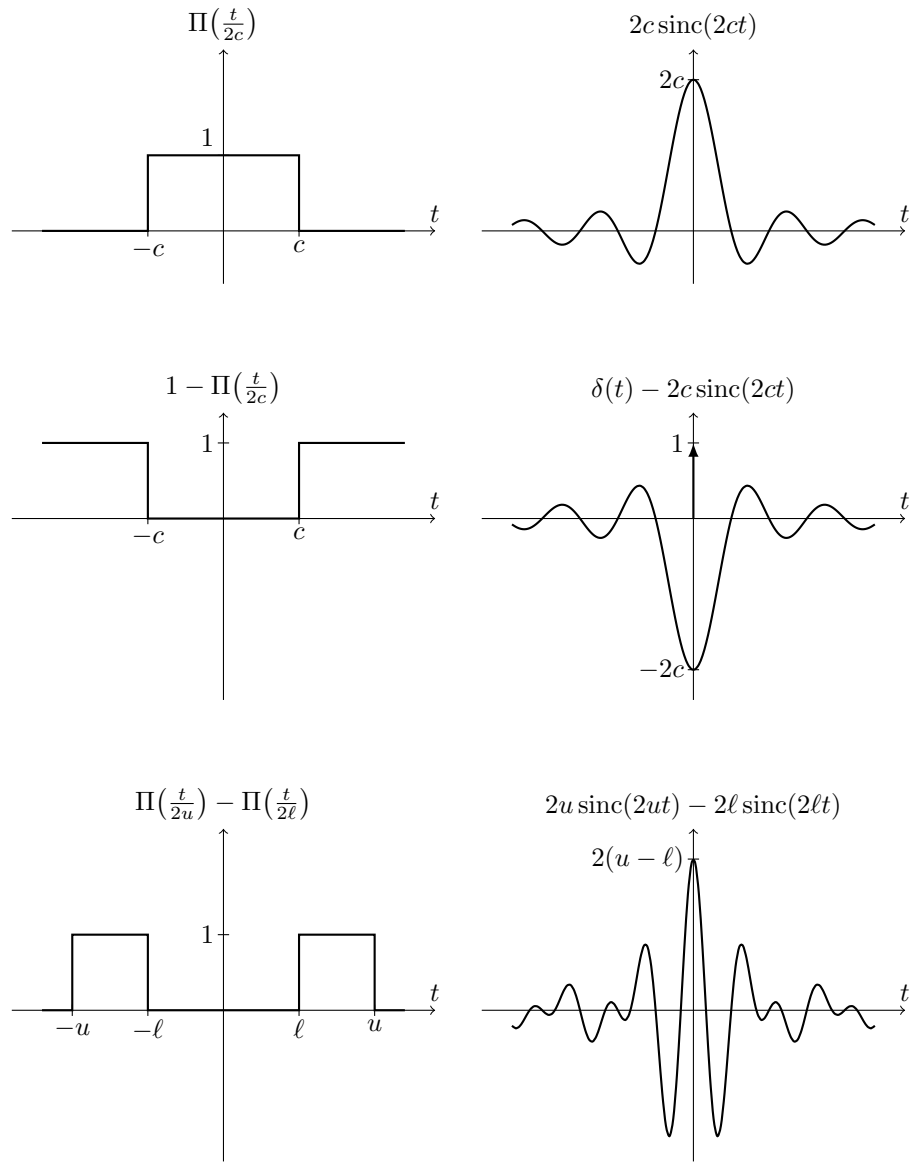

Figure 41: Spectrum and impulse response of the ideal lowpass filter L_c (top), the ideal highpass filter $T_0 - L_c$ (middle), and the ideal bandpass filter $L_u - L_\ell$ (bottom). The ideal highpass filter is not regular and does not have an impulse response. We plot the 'pretend' impulse response using the delta function described in Section 3.1.

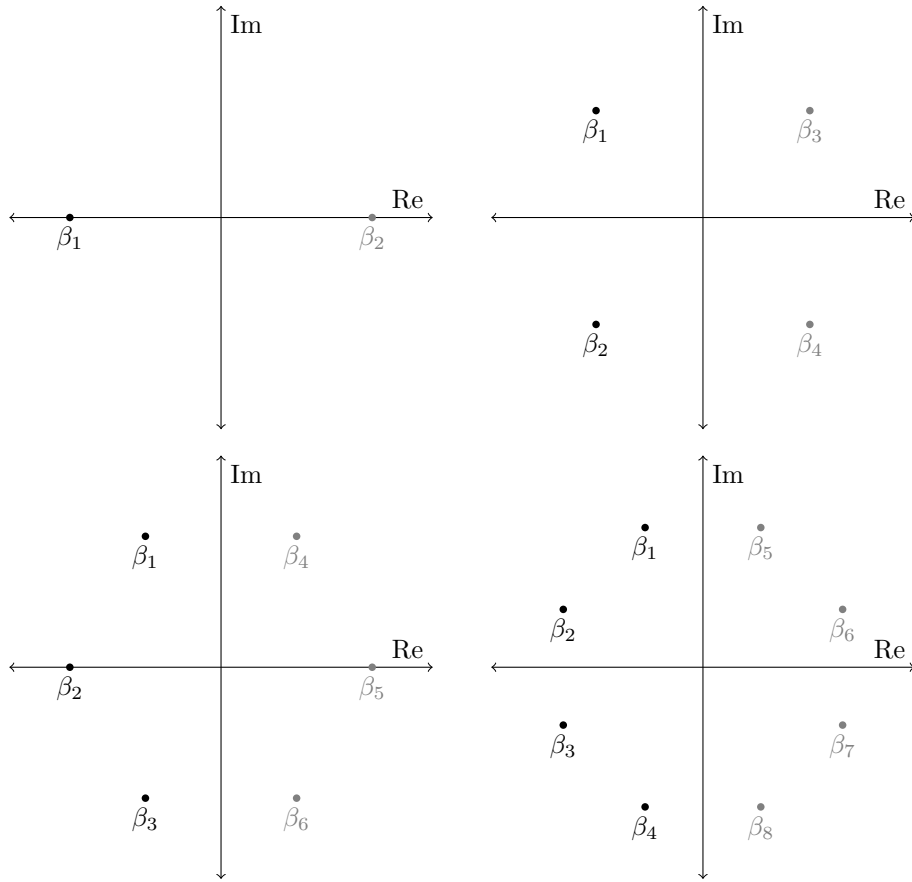

Figure 42: Roots of the polynomial $s^{2m} + (-1)^m$ for $m = 1$ (top left), $m = 2$ (top right), $m = 3$ (bottom left), and $m = 4$ (bottom right). All the roots lie on the complex unit circle and have magnitude one. The poles of the normalised Butterworth filter B_m are those roots from the left half of the complex plane (unshaded).

The squared magnitude of the polynomial on the denominator is

$$\begin{aligned} \left| \prod_{i=1}^m (jf - \beta_i) \right|^2 &= \left(\prod_{i=1}^m (jf - \beta_i) \right) \left(\prod_{i=1}^m (jf - \beta_i) \right)^* \\ &= \prod_{i=1}^m (jf - \beta_i)(jf - \beta_i)^* \\ &= \prod_{i=1}^m (jf - \beta_i)j^*(f - (\beta_i/j)^*) \end{aligned}$$

and because $j^*/j = -1$ we have

$$\begin{aligned} \left| \prod_{i=1}^m (jf - \beta_i) \right|^2 &= (-1)^m \prod_{i=1}^m (jf - \beta_i)(jf - j(\beta_i/j)^*) \\ &= (-1)^m \prod_{i=1}^m (jf - \beta_i)(jf - \beta_{m+i}) \\ &= (-1)^m \prod_{i=1}^{2m} (jf - \beta_i). \end{aligned}$$

Because $\beta_1, \dots, \beta_{2m}$ are the roots of the polynomial $s^{2m} + (-1)^m$ we have

$$\left| \prod_{i=1}^m (jf - \beta_i) \right|^2 = (-1)^m ((jf)^{2m} + (-1)^m) = f^{2m} + 1.$$

It follows that the magnitude spectrum of B_m is

$$|\Lambda(B_m)| = \sqrt{\frac{1}{f^{2m} + 1}}.$$

The magnitude and phase spectrum of the filters B_1 , B_2 , B_3 , and B_4 are plotted in Figure 43.

The **cutoff frequency** of the lowpass filter B_m is defined as the positive real number c such that $|\Lambda(B_m, f)|^2 < \frac{1}{2}$ for all $f > c$. The normalised Butterworth filters have cutoff frequency $c = 1\text{Hz}$. A lowpass Butterworth filter of order m and cutoff frequency c , denoted B_m^c , has transfer function

$$\lambda(B_m^c, s) = \lambda(B_m, \frac{s}{c}) = \frac{1}{\prod_{i=1}^m (\frac{s}{2\pi c} - \beta_i)}.$$

The magnitude spectrum satisfies

$$|\Lambda(B_m^c, f)|^2 = |\Lambda(B_m, \frac{f}{c})|^2 = \frac{1}{(\frac{f}{c})^{2m} + 1} = \frac{c^{2m}}{f^{2m} + c^{2m}}. \quad (5.12)$$

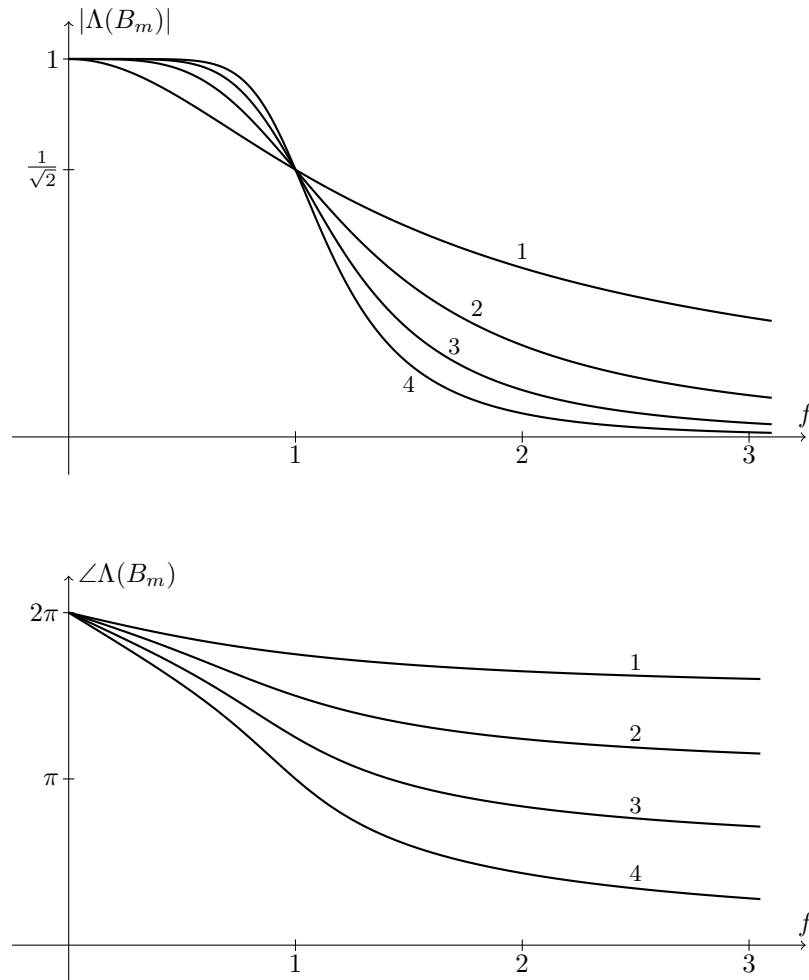

Figure 43: Magnitude spectrum (top) and phase spectrum (bottom) of normalised Butterworth filters B_1, B_2, B_3 and B_4 .

A first order Butterworth filter B_1^c has spectrum

$$\Lambda(B_1^c) = \frac{1}{j\frac{f}{c} + 1} = \frac{c}{jf + c}.$$

Putting $\frac{1}{c} = 2\pi RC$ we find that this is the same as the spectrum of the RC electrical circuit (Figure 10) or the active RC circuit after negation (3.8). Thus, the RC electrical circuit is a first order Butterworth filter with cutoff frequency $c = \frac{1}{2\pi RC}$. In Test 4 we constructed the active RC circuit with $R \approx 27\text{k}\Omega$ and $C \approx 10\text{nF}$ and measured its magnitude spectrum. The cutoff frequency was $c = \frac{5 \times 10^4}{27\pi} \approx 589\text{Hz}$.

A second order electrical Butterworth filter can be constructed using the Sallen-Key circuit described in Section 2.2 and Figure 20. The input voltage x and output voltage y of the Sallen-Key satisfy the differential equation (2.13)

$$x = y + C_2(R_1 + R_2)D(y) + R_1R_2C_1C_2D^2(y).$$

The transfer function is

$$\frac{\mathcal{L}(y)}{\mathcal{L}(x)} = \frac{1}{1 + C_2(R_1 + R_2)s + R_1R_2C_1C_2s^2}.$$

The second order Butterworth filter B_2^c has transfer function

$$\Lambda(B_m^c) = \frac{1}{(\frac{1}{2\pi c}s - \beta_1)(\frac{1}{2\pi c}s - \beta_2)},$$

where $\beta_1 = \beta_2^* = e^{j3\pi/4}$. Expanding the quadratic on the denominator gives

$$\Lambda(B_m^c) = \frac{1}{1 + \frac{1}{\sqrt{2}\pi c}s + \frac{1}{4\pi^2 c^2}s^2}.$$

Choosing the resistors and capacitors of the Sallen-Key to satisfy

$$C_2(R_1 + R_2) = \frac{1}{\sqrt{2}\pi c}, \quad R_1R_2C_1C_2 = \frac{1}{4\pi^2 c^2}$$

leads to a second order Butterworth filter. A convenient solution is to put $C_1 = 2C_2$ and $R_1 = R_2$. This gives a second order Butterworth filter with cutoff

$$c = \frac{1}{\sqrt{2}\pi C_2(R_1 + R_2)} = \frac{1}{\sqrt{2}\pi C_1 R_1}.$$

In Test 6 we construct a second order Butterworth filter using a Sallen-Key and measure its magnitude spectrum.

Butterworth filters of orders larger than $m = 2$ can be constructed by concatenating Sallen-Key circuits and RC circuits. If m is even then $m/2$ Sallen-Key circuits are required. Each Sallen-Key is used to construct a conjugate pair of poles, that is, the k th Sallen-Key would have poles $2\pi c\beta_k$ and $2\pi c\beta_k^* = 2\pi c\beta_{m-k+1}$. If m is odd then $(m-1)/2$ Sallen-Key circuits and a single RC circuit (or active RC circuit) can be used. The RC circuit is designed to have the real valued pole $\beta_{(m+1)/2} = 2\pi c$.

Test 6 (Butterworth filter)

We construct a second order Butterworth filter using the Sallen-Key circuit from Figure 20 with capacitors $C_2 \approx 100\text{nF}$, $C_1 \approx 2C_2 \approx 200\text{nF}$ and resistors $R_1 \approx R_2 \approx 1000\Omega$. The cutoff frequency is

$$c = \frac{1}{\sqrt{2}\pi C_1 R_1} \approx 1125\text{Hz}.$$

Sinusoids of the form

$$\sin(2\pi f_k t), \quad f_k = 110 \times 2^{k/2}, \quad k = 0, 1, \dots, 12$$

are input to the filter using a computer soundcard and the magnitude spectrum is measured using the method described in Test 4. Figure 44 shows the measurements (dots) plotted alongside the hypothesised spectrum

$$|\Lambda(B_2^c)| = \sqrt{\frac{1}{(f/1125)^4 + 1}}.$$

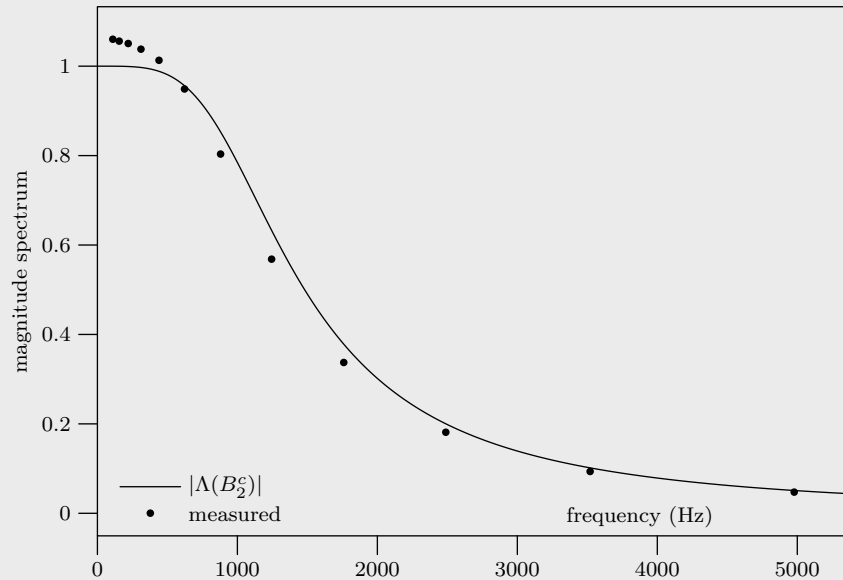

Figure 44: Plot of the hypothesised magnitude spectrum of the second order Butterworth filter $|\Lambda(B_m^c)|$ (solid line) and of the measured magnitude spectrum of the filter implemented with a Sallen-Key active electrical circuit (dots).

5.5 Sampling and interpolation

Let x be a signal with Fourier transform $\hat{x} = \mathcal{F}(x)$ and let

$$\hat{x}_p(f) = \sum_{m \in \mathbb{Z}} \hat{x}(f - m). \quad (5.13)$$

The signal \hat{x}_p is periodic with period one since for every integer k ,

$$\hat{x}_p(f - k) = \sum_{m \in \mathbb{Z}} \hat{x}(f - k - m) = \sum_{m \in \mathbb{Z}} \hat{x}(f - m) = \hat{x}_p(f).$$

For this reason \hat{x}_p is sometimes called the **periodised** or **wrapped** version of \hat{x} [Fisher and Lee, 1994]. We plot functions \hat{x} and their periodised versions \hat{x}_p in Figure 44.

Assume that we can write the periodic signal $\hat{x}_p(f)$ as a series

$$\hat{x}_p(f) = \sum_{n \in \mathbb{Z}} x_n e^{-j2\pi f n}. \quad (5.14)$$

The coefficients x_n in this series can be recovered by

$$x_n = \int_{-1/2}^{1/2} \hat{x}_p(f) e^{2\pi j f n} df. \quad (5.15)$$

To see this write

$$\begin{aligned} \int_{-1/2}^{1/2} \hat{x}_p(f) e^{2\pi j f n} df &= \int_{-1/2}^{1/2} \left(\sum_{m \in \mathbb{Z}} x_m e^{-j2\pi f m} \right) e^{2\pi j f n} df \\ &= \sum_{m \in \mathbb{Z}} x_m \int_{-1/2}^{1/2} e^{-j2\pi f m} e^{j2\pi f n} df \\ &= \sum_{m \in \mathbb{Z}} x_m \int_{-1/2}^{1/2} e^{j2\pi f (n-m)} df \\ &= \sum_{m \in \mathbb{Z}} x_m \operatorname{sinc}(n - m) \\ &= x_n \end{aligned}$$

because $\operatorname{sinc}(n - m) = 1$ when $n = m$ and zero otherwise. The periodic function \hat{x}_p is called the **discrete Fourier transform** of the sequence x_n .

Substituting (5.13) into (5.15) we obtain

$$x_n = \int_{-1/2}^{1/2} \sum_{m \in \mathbb{Z}} \hat{x}(f - m) e^{2\pi j f n} df = \sum_{m \in \mathbb{Z}} \int_{-1/2}^{1/2} \hat{x}(f - m) e^{2\pi j f n} df.$$

By the change of variable $\gamma = f - m$ we obtain

$$\begin{aligned}
x_n &= \sum_{m \in \mathbb{Z}} \int_{-1/2-m}^{1/2-m} \hat{x}(\gamma) e^{2\pi j n (\gamma+m)} d\gamma \\
&= \sum_{m \in \mathbb{Z}} \int_{-1/2-m}^{1/2-m} \hat{x}(\gamma) e^{2\pi j n \gamma} d\gamma && \text{(since } e^{2\pi j m} = 1) \\
&= \int_{-\infty}^{\infty} \hat{x}(\gamma) e^{2\pi j n \gamma} d\gamma \\
&= \mathcal{F}^{-1}(\hat{x}, n) \\
&= x(n).
\end{aligned}$$

Thus, the sequence x_n corresponds with the signal x sampled at the integers, that is $x_n = x(n)$.

A signal x is called **bandlimited** if there exists a positive real number b such that $\mathcal{F}(x, f) = 0$ for all $|f| > b$. For example, the sinc function is bandlimited with bandwidth $\frac{1}{2}$ because its Fourier transform $\mathcal{F}(\text{sinc}, f) = \Pi(f) = 0$ for all $|f| > \frac{1}{2}$. The value b is referred to as the **bandwidth** of the signal x . If x is bandlimited with bandwidth $b \leq \frac{1}{2}$, then x can be recovered from its samples at the integers, that is, x can be recovered from the sequence x_n . To see this, first observe that

$$\Pi(f) \hat{x}(f - m) = \begin{cases} \hat{x}(f) & m = 0 \\ 0 & \text{otherwise} \end{cases}$$

since $\hat{x}(f) = 0$ whenever $|f| \geq \frac{1}{2}$. Now, multiplying $\hat{x}_p(f)$ by the rectangle function gives

$$\Pi(f) \hat{x}_p(f) = \sum_{m \in \mathbb{Z}} \Pi(f) \hat{x}(f - m) = \hat{x}(f).$$

Now consider the signal

$$\tilde{x}(t) = \sum_{n \in \mathbb{Z}} x_n \text{sinc}(t - n).$$

Taking the Fourier transform on both sides gives

$$\begin{aligned}
\mathcal{F}(\tilde{x}) &= \mathcal{F}\left(\sum_{n \in \mathbb{Z}} x_n \text{sinc}(t - n)\right) \\
&= \sum_{n \in \mathbb{Z}} x_n \mathcal{F}(\text{sinc}(t - n)) \\
&= \sum_{n \in \mathbb{Z}} x_n e^{-j2\pi f n} \Pi(f) && \text{(time shift property of } \mathcal{F}) \\
&= \Pi(f) \hat{x}_p(f) && \text{(from (5.14))} \\
&= \hat{x}(f) \\
&= \mathcal{F}(x, f).
\end{aligned}$$

Thus, $\mathcal{F}(\tilde{x}) = \mathcal{F}(x)$ and application of the inverse Fourier transform reveals that $\tilde{x} = x$, that is

$$x(t) = \sum_{n \in \mathbb{Z}} x_n \operatorname{sinc}(t - n).$$

If instead of sampling at the integers we sample at rate F_s so that $x_n = x(F_s n)$, then, by a similar argument, we find that x can be recovered as

$$x(t) = \sum_{n \in \mathbb{Z}} x_n \operatorname{sinc}(F_s t - n)$$

provided that x is bandlimited with bandwidth $F_s/2$. This is called the **Nyquist criterion**.

5.6 Exercises

5.1. Plot the signal $e^{-\alpha|t|}$ where $\alpha > 0$ and find its Fourier transform. **Solution:**

$$\begin{aligned} \mathcal{F}(e^{-\alpha|t|}) &= \int_{-\infty}^{\infty} e^{-\alpha|t|} e^{-j2\pi f t} dt \\ &= \int_0^{\infty} e^{-\alpha t} e^{-j2\pi f t} dt + \int_{-\infty}^0 e^{\alpha t} e^{-j2\pi f t} dt \\ &= \int_0^{\infty} e^{-(j2\pi f + \alpha)t} dt + \int_{-\infty}^0 e^{-(j2\pi f - \alpha)t} dt \\ &= \left[\frac{e^{-(j2\pi f + \alpha)t}}{-(j2\pi f + \alpha)} \right]_0^{\infty} + \left[\frac{e^{-(j2\pi f - \alpha)t}}{-(j2\pi f - \alpha)} \right]_{-\infty}^0. \end{aligned}$$

Because $\alpha > 0$, the limits as $t \rightarrow \infty$ and $t \rightarrow -\infty$ go to zero leaving

$$\frac{1}{j2\pi f + \alpha} - \frac{1}{j2\pi f - \alpha} = \frac{j2\pi f + \alpha - j2\pi f + \alpha}{(j2\pi f + \alpha)(j2\pi f - \alpha)} = \frac{2\alpha}{4\pi^2 f^2 + \alpha^2}.$$

5.2. Plot the signal

$$\Delta(t) = \begin{cases} t + 1 & -1 \leq t < 0 \\ 1 - t & 0 \leq t < 1 \\ 0 & \text{otherwise} \end{cases}$$

and find its Fourier transform. **Solution:** This signal is often called the **triangle function** or **triangle pulse**.

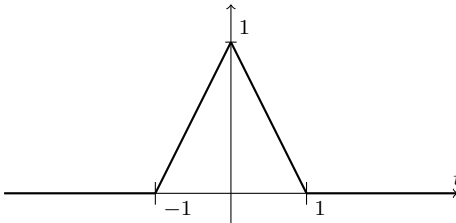

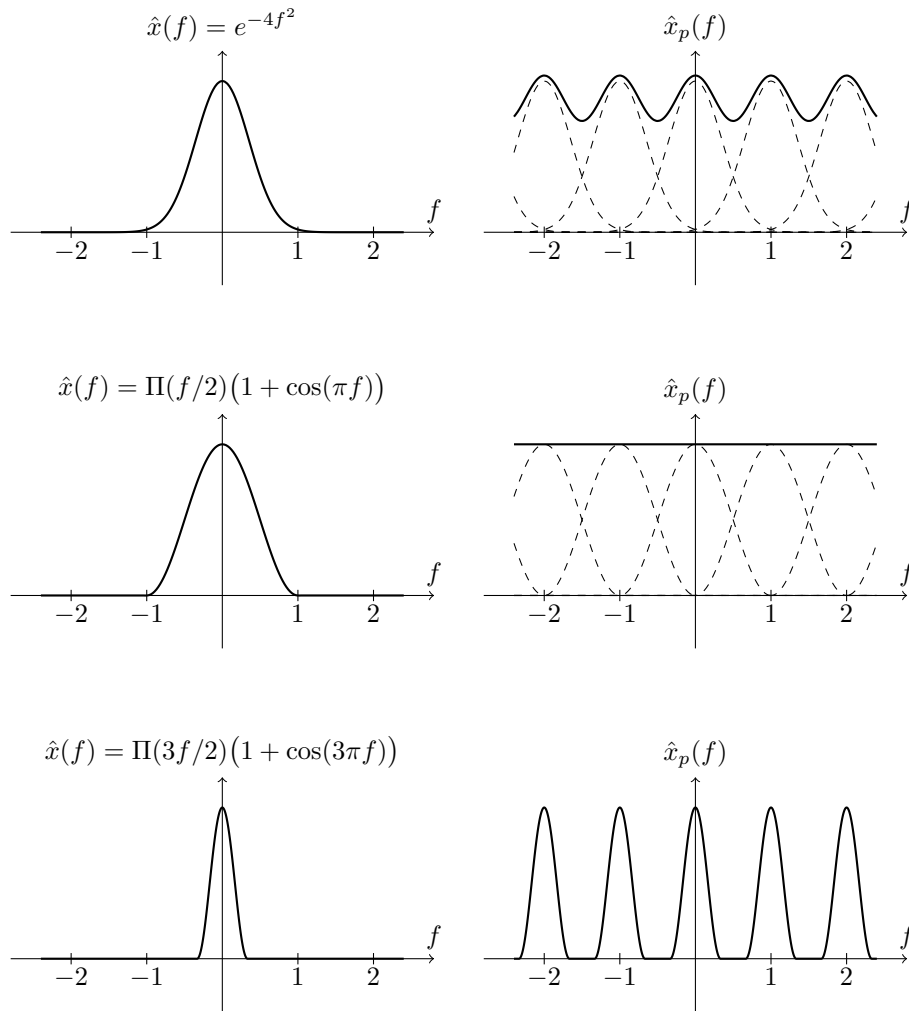

Figure 44: Signals \hat{x} and their periodised versions \hat{x}_p . Aliasing occurs in the plot on the top and middle. No aliasing occurs in the plot on the bottom.

You can do this directly using the formula for the Fourier transform and integrating by parts. However, it is easier to first realise that the triangle pulse is the convolution of the rectangular function with itself. That is $\Pi * \Pi = \Delta$. To see this write

$$(\Pi * \Pi)(t) = \int_{-\infty}^{\infty} \Pi(\tau)\Pi(t - \tau)d\tau = \int_{-1/2}^{1/2} \Pi(t - \tau)d\tau$$

Now $\Pi(t - \tau) = 1$ for τ in the interval $(-\frac{1}{2} + t, \frac{1}{2} + t)$ and zero otherwise. Thus, the integral evaluates to zero if $t \geq 1$ or $t \leq -1$. When $t \in [-1, 0)$

$$(\Pi * \Pi)(t) = \int_{-1/2}^{1/2+t} d\tau = t + 1$$

and when $t \in [0, 1)$

$$(\Pi * \Pi)(t) = \int_{-1/2+t}^{1/2} d\tau = 1 - t$$

as required. Now, by the convolution theorem (5.3)

$$\mathcal{F}(\Pi * \Pi) = \mathcal{F}(\Delta) = \mathcal{F}(\Pi)\mathcal{F}(\Pi) = \text{sinc}^2(t).$$

- 5.3. Show that the sinc function is square integrable, but not absolutely integrable. **Solution:** Our proof is by contradiction. Assume that sinc is absolutely integrable. Then

$$\begin{aligned} \|\text{sinc}\|_1 &= \int_{-\infty}^{\infty} |\text{sinc}(t)| dt \\ &> \int_0^{\infty} |\text{sinc}(t)| dt \\ &= \sum_{n=1}^{\infty} \int_{n-1}^n \left| \frac{\sin(\pi t)}{\pi t} \right| dt \\ &= \sum_{n=1}^{\infty} a_n \end{aligned}$$

where we put

$$a_n = \int_{n-1}^n \left| \frac{\sin(\pi t)}{\pi t} \right| dt.$$

Under our assumption that sinc is absolutely integrable we must have that the infinite sum $a_1 + a_2 + \dots$ converge to a finite number. Now

$$a_n \geq \int_{n-1}^n \left| \frac{\sin(\pi t)}{\pi n} \right| dt = \frac{1}{\pi n} \int_{n-1}^n |\sin(\pi t)| dt = \frac{2}{\pi^2 n}.$$

However, the sum

$$\sum_{n=1}^{\infty} a_n = \frac{2}{\pi^2} \sum_{n=1}^{\infty} \frac{1}{n}$$

involves the harmonic series (a p -series with $p = 1$) and so diverges (to show this use either an integral test or the condensation test). Thus, our initial hypothesis that sinc is absolutely integrable is false.

Graphically, the argument we have used bounds $|\text{sinc}|$ above the function

$$b(t) = \begin{cases} 0 & t \leq 0 \\ \left| \frac{\sin(\pi t)}{\pi n} \right| & t \in (n-1, n] \end{cases}$$

and then shows that b is not absolutely integrable. The function $|\text{sinc}|$ (dashed) and b (solid) are plotted in the figure below.

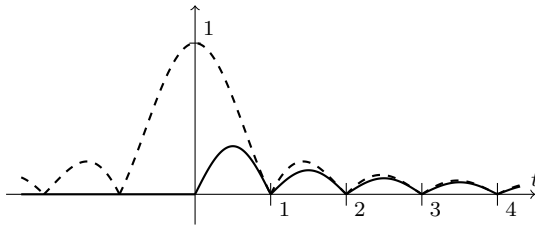

To show that sinc is square integrable observe that $\text{sinc}^2(t)$ is bounded below the function

$$g(t) = \begin{cases} 1 & |t| \leq 1 \\ \frac{1}{t^2} & \text{otherwise,} \end{cases}$$

that is $\text{sinc}^2(t) \leq g(t)$ for all $t \in \mathbb{R}$. Thus

$$\begin{aligned} \|\text{sinc}\|_2 &= \int_{-\infty}^{\infty} |\text{sinc}(t)|^2 dt \\ &\leq \int_{-\infty}^{\infty} g(t) dt \\ &= \int_{-1}^1 dt + 2 \int_1^{\infty} \frac{1}{t^2} \\ &= 2 - \left[\frac{1}{t} \right]_1^{\infty} = 2 + 1 = 3. \end{aligned}$$

The figure below plots sinc^2 (dashed) and the bounding function g .

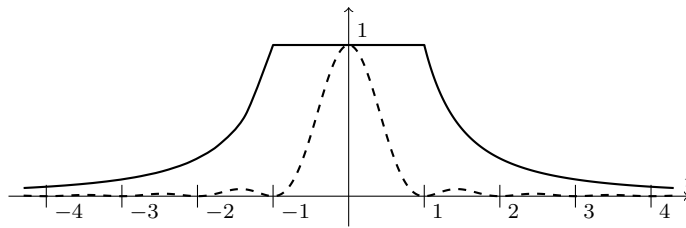

5.4. Find and plot the impulse response of the normalised lowpass Butterworth filters B_1 , B_2 and B_3 .

5.5. Plot the signal

$$t\Pi(t) = \begin{cases} t & -\frac{1}{2} < t \leq \frac{1}{2} \\ 0 & \text{otherwise} \end{cases}$$

and find its Fourier transform. **Solution:**

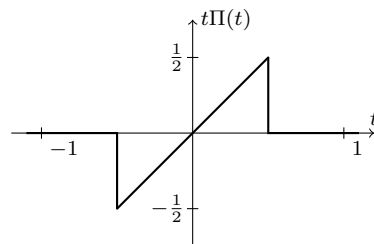

A direct approach is

$$\mathcal{L}(t\Pi(t)) = \int_{-\infty}^{\infty} t\Pi(t)e^{-st}dt = \int_{-1/2}^{1/2} te^{-st}dt$$

and integrating by parts gives

$$\begin{aligned} \mathcal{L}(t\Pi(t)) &= \left[t \frac{e^{-st}}{-s} \right]_{-1/2}^{1/2} - \int_{-1/2}^{1/2} \frac{e^{-st}}{-s} dt \\ &= \frac{e^{-s/2} + e^{s/2}}{-2s} - \left[\frac{e^{-st}}{s^2} \right]_{-1/2}^{1/2} \\ &= \frac{e^{-s/2} + e^{s/2}}{-2s} - \frac{e^{-s/2} - e^{s/2}}{s^2} \\ &= \frac{1}{s} \left(-\frac{e^{s/2} + e^{-s/2}}{2} + \frac{e^{s/2} - e^{-s/2}}{s} \right). \end{aligned}$$

Because $t\Pi(t)$ is absolutely integrable its region of convergence includes the imaginary axis and we can obtain the Fourier transform by evaluating the Laplace transform at $s = j2\pi f$,

$$\begin{aligned} \mathcal{F}(t\Pi(t), f) &= \mathcal{L}(x, j2\pi f) \\ &= \frac{1}{2\pi j f} \left(-\frac{e^{j\pi f} + e^{-j\pi f}}{2} + \frac{e^{j\pi f} - e^{-j\pi f}}{2j\pi f} \right) \\ &= \frac{1}{2\pi j f} (\text{sinc}(f) - \cos(\pi f)). \end{aligned}$$

An alternative approach is to observe that

$$\mathcal{F}(D(\text{sinc})) = \Lambda(D)\mathcal{F}(\text{sinc}) = j2\pi f\Pi(f),$$

and so, by duality,

$$\mathcal{F}(j2\pi t\Pi(t), f) = \mathcal{F}(\mathcal{F}(D(\text{sinc})), f) = D(\text{sinc}, -f)$$

The derivative of the sinc function is given in (2.9)

$$D(\text{sinc}, -f) = \frac{1}{\pi f^2} (\sin(\pi f) - \pi f \cos(\pi f)) = \frac{1}{f} (\text{sinc}(f) - \cos(\pi f)).$$

Dividing by $j2\pi$ we obtain

$$\mathcal{F}(t\Pi(t), f) = \frac{1}{2j\pi^2 f^2} (\pi f \cos(\pi f) - \sin(\pi f)) = \frac{1}{2j\pi f} (\text{sinc}(f) - \cos(\pi f))$$

again. A plot of the Fourier transform is below. Observe that the Fourier transform is purely imaginary so we plot the imaginary part.

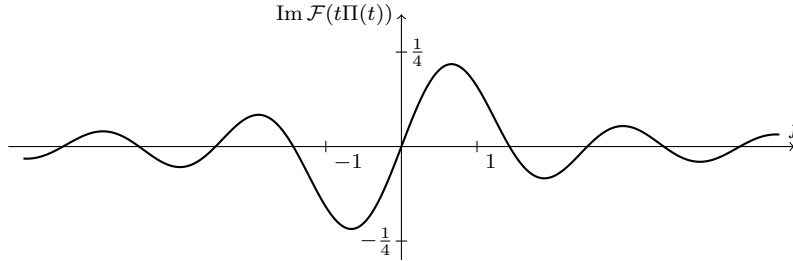

- 5.6. Plot the signal $\Pi(t)(1 + \cos(2\pi t))$ and find its Fourier transform. Plot the Fourier transform. **Solution:**

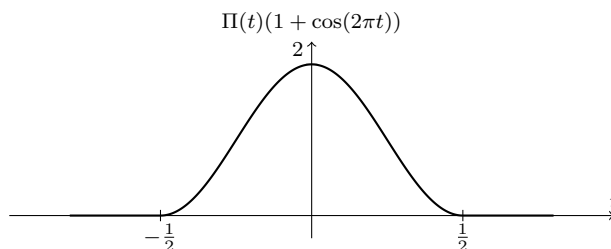

Put $x(t) = \Pi(t)(1 + \cos(2\pi t))$. It is convenient to construct what is called the **analytic signal**

$$x_a(t) = \Pi(t)(1 + e^{2\pi j t})$$

that has the property $x = \text{Re}(x_a) = \frac{1}{2}(x_a + x_a^*)$. We have

$$\mathcal{F}(x_a^*, f) = \mathcal{F}(x_a, -f)^*$$

from (5.10). Now, by the modulation property

$$\hat{x}_a(f) = \mathcal{F}(x_a, f) = \mathcal{F}(\Pi(t)) + \mathcal{F}(\Pi(t)e^{2\pi j t}) = \text{sinc}(f) + \text{sinc}(f - 1),$$

and so,

$$\begin{aligned} \mathcal{F}(x) &= \frac{1}{2}\mathcal{F}(x_a + x_a^*) \\ &= \frac{1}{2}\hat{x}_a(f) + \frac{1}{2}\hat{x}_a(-f)^* \\ &= \text{sinc}(f) + \frac{1}{2}\text{sinc}(f - 1) + \frac{1}{2}\text{sinc}(f + 1). \end{aligned}$$

A plot of the Fourier transform is below. The shape of the Fourier transform is somewhat sinc-like, but the oscillations decay much faster as $|f| \rightarrow \infty$.

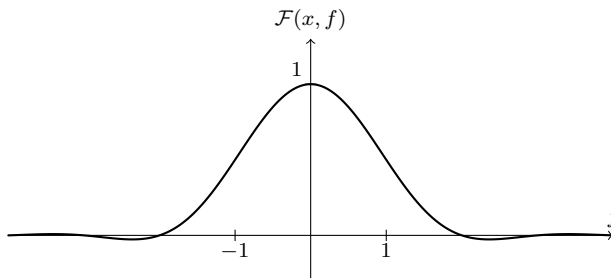

- 5.7. Let x be an absolutely integrable signal and let $x_p(t) = \sum_{m \in \mathbb{Z}} x(t - m)$ be its periodised version. Show that x_p is a periodic signal satisfying

$\int_{-1/2}^{1/2} |x_p(t)| dt < \infty$. **Solution:** We have

$$\begin{aligned} \int_{-1/2}^{1/2} |x_p(t)| dt &= \int_{-1/2}^{1/2} \left| \sum_{m \in \mathbb{Z}} x(t-m) \right| dt \\ &\leq \int_{-1/2}^{1/2} \sum_{m \in \mathbb{Z}} |x(t-m)| dt \\ &= \sum_{m \in \mathbb{Z}} \int_{-1/2}^{1/2} |x(t-m)| dt \\ &= \sum_{m \in \mathbb{Z}} \int_{-1/2-m}^{1/2-m} |x(\tau)| d\tau \quad (\text{change variable } \tau = t-m) \\ &= \int_{-\infty}^{\infty} |x(\tau)| d\tau < \infty \end{aligned}$$

because x is absolutely integrable.

5.8. State whether the following signals are bandlimited and, if so, find the bandwidth.

- (a) $\text{sinc}(4t)$,
- (b) $\Pi(t/4)$,
- (c) $\cos(2\pi t) \text{sinc}(t)$,
- (d) $e^{-|t|}$.

Solution: Let $S_\alpha(x, t) = x(\alpha t)$ be the time scaler system. We have

$$\begin{aligned} \mathcal{F}(S_\alpha(x), f) &= \int_{-\infty}^{\infty} x(\alpha t) e^{-2\pi j f t} dt \\ &= \frac{1}{\alpha} \int_{-\infty}^{\infty} x(\gamma) e^{-2\pi j f \gamma / \alpha} d\gamma \quad (\text{ch. var. } \gamma = \alpha t) \\ &= \frac{1}{\alpha} \mathcal{F}(x, f/\alpha) \\ &= \frac{1}{\alpha} S_{1/\alpha}(\mathcal{F}(x), f). \end{aligned}$$

The Fourier transform of $S_\alpha(\text{sinc})(t) = \text{sinc}(4t)$ is

$$\mathcal{F}(\text{sinc}(4t)) = \frac{1}{4} \Pi(f/4),$$

and the signal is bandlimited with bandwidth 2 because $\Pi(f/4) = 0$ whenever $|f| > 2$.

By duality

$$\frac{1}{4} \mathcal{F}(\Pi(f/4)) = \text{sinc}(4t)$$

and so $\mathcal{F}(\Pi(f/4)) = 4 \text{sinc}(4t)$. This signal is not bandlimited because the sinc function is unbounded in time. By the modulation property of Fourier transform (5.6),

$$\mathcal{F}(\cos(2\pi t) \text{sinc}(t), f) = \mathcal{F}(\text{sinc}, f-1) + \mathcal{F}(\text{sinc}, f+1) = \Pi(f-1) + \Pi(f+1).$$

This is bandlimited with bandwidth $\frac{3}{2}$. In Exercise 5.1 we showed that

$$\mathcal{F}(e^{-|t|}) = \frac{2}{4\pi^2 f^2 + 1}.$$

This signal is not bandlimited.

References

- Butterworth, S. [1930]. On the theory of filter amplifiers. *Experimental Wireless and the Wireless Engineer*, pp. 536–541.
- Curry, H. and Feys, R. [1968]. *Combinatory logic 1*. North-Holland, Amsterdam, Netherlands, 2nd edition.
- Fine, B. and Rosenberger, G. [1997]. *The Fundamental Theorem of Algebra*. Undergraduate Texts in Mathematics. Springer-Verlag, Berlin.
- Fisher, N. I. and Lee, A. J. [1994]. Time Series Analysis of Circular Data. *Journal of the Royal Statistical Society. Series B (Methodological)*, 56(2), 327–339.
- Nicholas, C. B. and Yates, R. C. [1950]. The Probability Integral. *Amer. Math. Monthly*, 57, 412–413.
- Nise, N. S. [2007]. *Control systems engineering*. Wiley, 5th edition.
- Oppenheim, A. V., Willsky, A. S. and Nawab, S. H. [1996]. *Signals and Systems*. Prentice Hall, 2nd edition.
- Papoulis, A. [1977]. *Signal analysis*. McGraw-Hill.
- Proakis, J. G. [2007]. *Digital communications*. McGraw-Hill, 5th edition.
- Rudin, W. [1986]. *Real and complex analysis*. McGraw-Hill.
- Sallen, R. and Key, E. [1955]. A practical method of designing RC active filters. *Circuit Theory, IRE Transactions on*, 2(1), 74–85.
- Stewart, I. and Tall, D. O. [2004]. *Complex Analysis*. Cambridge University Press.
- Zemanian, A. H. [1965]. *Distribution theory and transform analysis*. Dover books on mathematics. Dover.